

KOBOLD KAL-D Series Thermal Flow Switch User Instructions



USA
1801 Parkway View Drive
Pittsburgh, PA 15205
Ph: 412-788-2830

CANADA
9A Aviation
Point-Claire, QC H9R 4Z2
Ph: 514-428-8090

www.koboldusa.com

KAL-D_manual_10-30-13

Table of Contents

1.0	General	1
2.0	Specifications.	1
3.0	Mechanical Installation.	3
4.0	Electrical Connections	4
5.0	Operation	6
5.1	Calibration	6
5.2	Flow Setpoint Adjustment.	8
5.3	Switch Operation.	8
5.4	KAL-D Diagnostics and Troubleshooting	9
6.0	Maintenance.	9
7.0	Arrival of Damaged Equipment	9
8.0	Need Help With Your KAL-D	9

List of Diagrams

Diagram 2.1	Dimensions.	3
Diagram 3.1	Mechanical Installation.	3
Diagram 4.1	Electrical Connections	4
Diagram 4.2	KAL-D Wiring	5
Diagram 5.1	KAL-D Displays and Controls.	6

List of Tables

Table 2.1	Approximate Switching Ranges Vs. Pipe Diameter.	2
-----------	---	---

CAUTION: For safety reasons, please read the cautionary information located at the end of the manual, before attempting installation.

1.0 General

The KOBOLD KAL-D flow switch is intended for use in monitoring and control applications involving moderate flowrates of water based, non-viscous clean or dirty liquids. The KAL-D flow switch uses the proven thermal dispersion principle and operates as follows:

1. The probe is heated internally to a few degrees above the temperature of the medium into which it extends.
2. As the medium flows past the probe it removes heat from the probe tip. The rate at which heat is removed is proportional to the flowrate.
3. The measured flowrate is compared to the setpoint value selected by the user. If the setpoint is reached, the electronic circuitry activates a transistor switch and bi-colored alarm LED. The electronic circuitry also controls an LED trend indicator which can be used to indicate relative system flow.

The microprocessor-controlled design permits simple calibration and setup. The compact probe design permits monitoring of flowrate with minimal head loss.

2.0 Specifications

Measuring Range:	0.05 - 2 meter/sec (0.15 to 6.6 Feet/Sec.)
Fitting Size:	1/2" NPT/BSP, 1/4" NPT/BSP or M-12 based on model number
Maximum Pressure:	580 PSIG
Maximum Temperature:	
Medium:	-4 to 176°F
Ambient:	0 to 150°F
Clean in Place (CIP):	250°F Max.
Supply Power:	24 VDC \pm 10%, 150mA Max.
Electrical Connection:	4-pin Micro-DC male
Wetted Parts:	316L SS
Housing:	304 SS NEMA 4X/ IP 65
Switching Characteristics:	
Switchpoint Adjustment:	By internal potentiometer
Switch Type:	NPN or PNP transistor Max. 24 VDC, 400mA, short circuit protected
Calibration Data:	Stored in non-volatile memory, data retained for at least 10 years in the event of power failure

Table 2.1 Approximate Switching Ranges Vs. Pipe Diameter

Nominal I.D Inches	Range GPM Water	Nominal I.D Inches	Range GPM Water
1/4"	0.02-1.0	3	3-140
1/2	0.1-4.0	4	5.2-250
3/4	0.2-9.0	6	12-575
1	0.3-15	8	21-1000
1-1/4	0.5-25	10	35-1600
1-1/2	0.75-35	12	50-2300
2	1.3-60	16	85-4000

IMPORTANT: The flow ranges specified in the table above have been calculated for each pipe diameter based upon the design velocity range of the KAL-D. It must be noted that flow in pipes is non-uniform across the pipe cross section, and approaches zero at the pipe wall. This means that, in practice, the installation depth of the probe, the internal pipe diameter, and the flow profile of the liquid in the pipe can interact to produce VERY significant deviations from the flow ranges in the above table.

Diagram 2.1 Dimensions (all dimensions in millimeters)

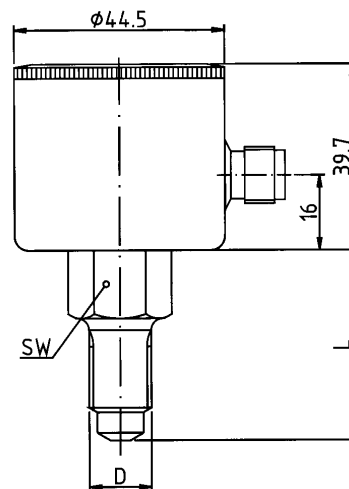
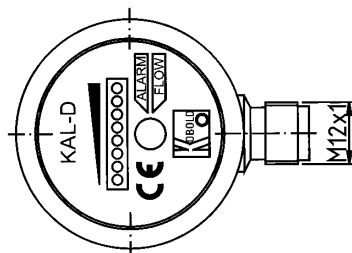

D	L	SW
1/4" NPT	40.5	19
1/2" NPT	40.5	27
1/4" BSP	40.5	19
1/2" BSP	40.5	27
M12 X 1	40.5	19

3.0 Mechanical Installation

To install the KAL-D flow switch into your piping system, proceed as follows:

- 3.0.1 The KAL-D flow switch can be mounted in virtually any orientation as long as the piping is completely filled with fluid. It is recommended that the unit be installed in the upper hemisphere of the pipe when being used in horizontal piping runs. This ensures that sediments do not deposit on the probe. It is also recommended that the unit not be installed in the top of the pipe on horizontal runs. This ensures that air pockets which collect in the top of the pipe do not cause false switching

Diagram 3.1 Mechanical Installation

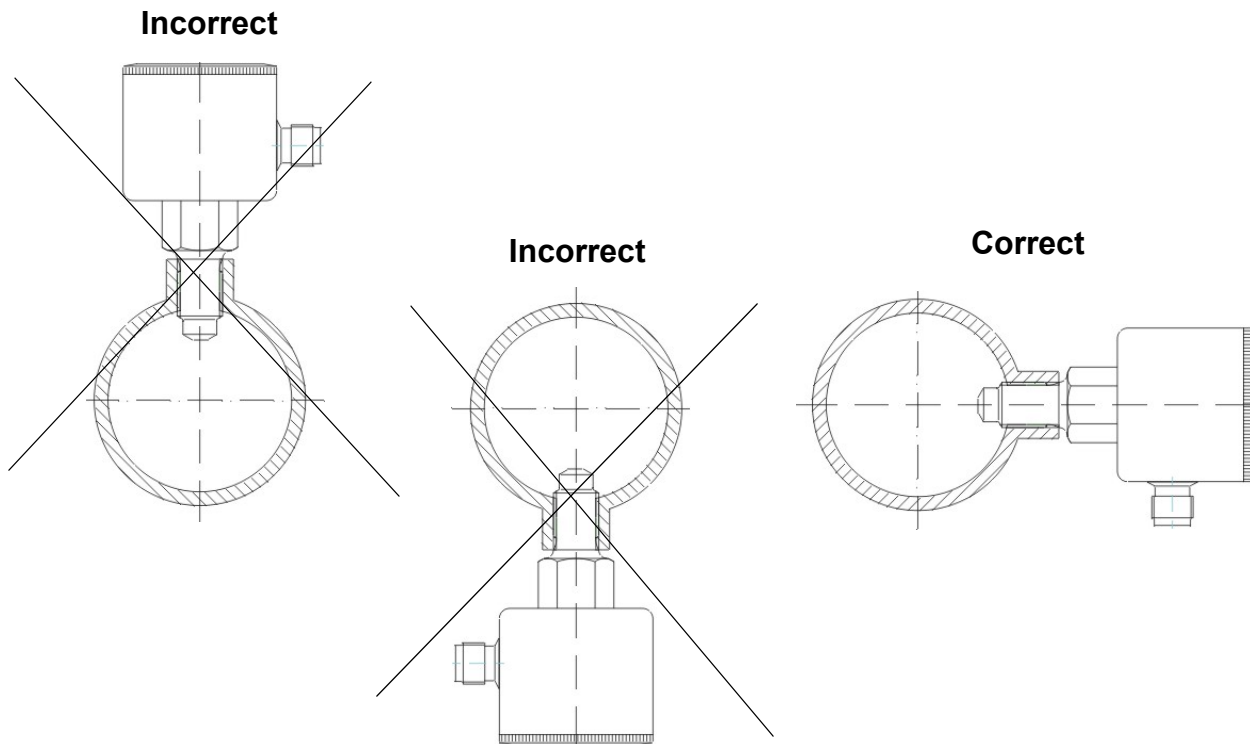

- 3.0.2 For optimal measuring accuracy, allow for 5 pipe diameters of straight-run piping both upstream and downstream of the flow switch. This ensures that flow profile at the sensing probe is uniform and fully developed.
- 3.0.3 Prior to installation, ensure that the desired flow alarm setpoint is within the switching range of the KAL-D. Additionally, ensure that the maximum system temperature and pressure are within the limits specified per Section 2.0, Specifications.
- 3.0.4 It is recommended that a thread sealant such as PTFE tape be applied to the probe threads to ensure a leaktight seal.
- 3.0.5 Using an appropriate sized wrench, carefully thread the sensor probe into the piping system. The probe must be installed such that at a minimum, the probe tip extends beyond the inner diameter of the piping and into the fluid stream.

Note: **Never use the housing to thread the unit into its fitting.** Always use only an appropriate sized wrench on the hex portion of the probe.

4.0 Electrical Connections

Electrical connections are made via a 4-pin Micro-DC plug. The KAL-D operates at a supply voltage of 24 VDC $\pm 10\%$ at a supply current of 150 mA. The power supply must be capable of supplying this current, plus any additional current required to drive the load.

Optional mating Connector

Brown = pin 1 = $+V_{\text{supply}}$

White = pin 2 = Not Connected

Blue = pin 3 = DC Ground

Black = pin 4 = Switch out

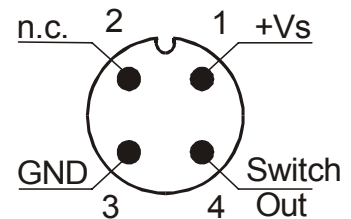

Diagram 4.1 Electrical Connections

Diagram 4.2 shows typical electrical wiring for the KAL-D configured as either a NPN or PNP transistor switch. The transistor switch output is configured as either an NPN or PNP open collector at the factory, based on the order code. It is not switchable from NPN to PNP or vice versa in the field.

The wire colors listed in Diagram 4.2 correspond to the color codes on the mating micro-DC plug with cable (sold separately).

Diagram 4.2 KAL-D Wiring

NPN Configuration

DC Ground switched to pin 4 when switch is activated. High impedance at pin 4 when switch is not activated.

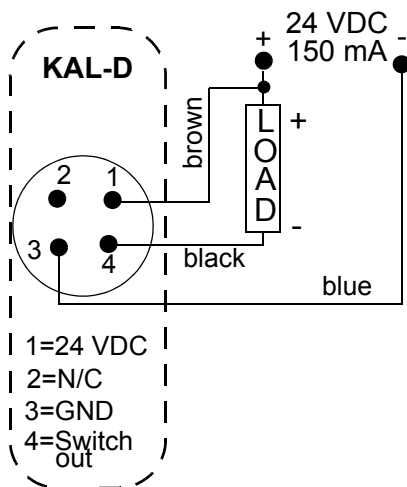

PNP Configuration

24 VDC is switched to pin 4 when switch is activated. High impedance at pin 4 when switch is not activated.

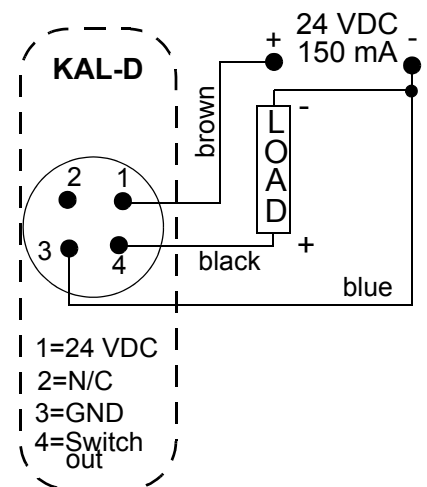

5.0 Operation

This section will provide details on the following aspects of KAL-D operation:

- Calibration of the zero-flow reference and trend indicator span.
- Adjustment of the flow switch setpoint.
- Computer self monitoring diagnostic routine within the KAL-D software.

Diagram 5.1 KAL-D Displays and Controls

Note: Unscrew top cover to access inside of KAL-D

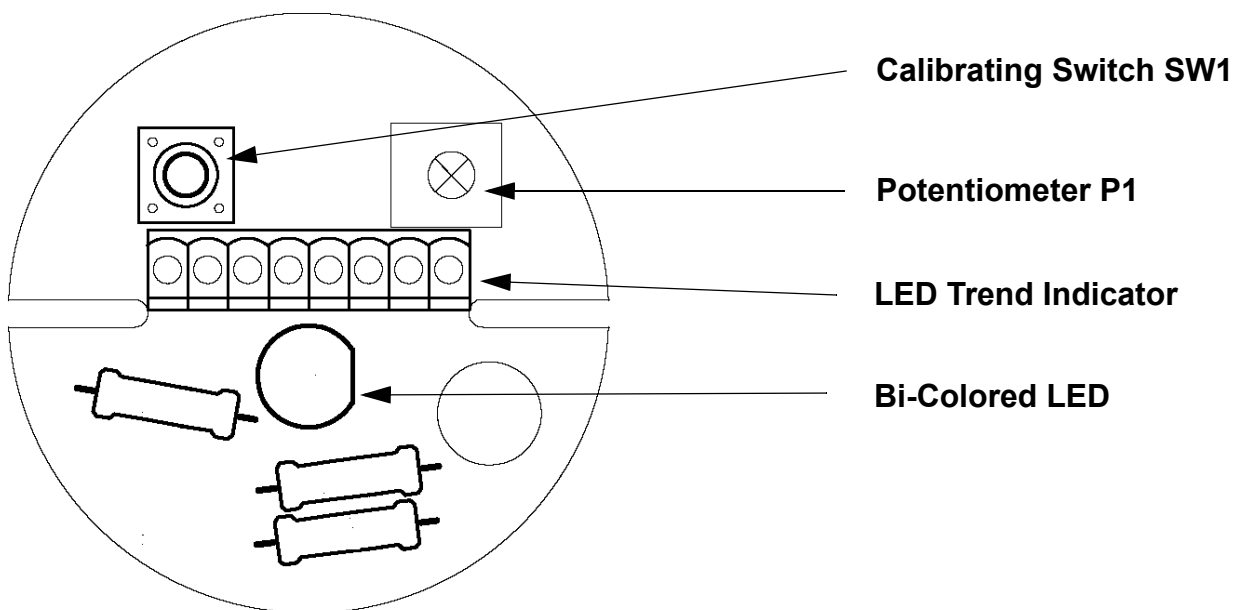

5.1 Calibration

5.1.1 Zero Flow Calibration

Calibration of the KAL-D electronics at zero system flow is necessary in order to obtain optimal performance from your KAL-D. This procedure is used to store data pertaining to the thermal characteristics of the fluid being monitored.

To perform the zero flow adjustment, refer to Diagram 5.1. Proceed as follows:

- 5.1.1.1 Ensure that the fluid system is in a no-flow condition.
- 5.1.1.2 Ensure that the system is completely filled and that the KAL-D sensing probe is completely immersed in fluid.

- 5.1.1.3 With power connected to the unit, turn the setpoint adjustment potentiometer P1 counterclockwise to its far lefthand stop.
- 5.1.1.4 Momentarily depress the calibrating switch SW1 and release. The bi-colored LED will flash green for a brief period while the unit is zeroing.

Note: Do not adjust the setpoint potentiometer P1 while the bi-colored LED is flashing. Doing this will invalidate the zero calibration and the procedure will have to be repeated.

- 5.1.1.5 When the bi-colored LED stops flashing, the zero flow calibration is complete.

5.1.2 Adjustment of the Trend Indicator Span

The KAL-D is factory preset at its maximum possible span. This span corresponds to a water flow velocity of 2 meters/second. This flow velocity will result in the illumination of all eight flow trend indicator LEDs. If the flow velocity in your system is significantly less than 2 meters/second, only two or three of the trend indicator LEDs may be lit during normal operation. The trend indicator span can be adjusted so that maximum system flow will result in a full span deflection of the flow trend indicator LEDs, thereby improving resolution.

To adjust the trend indicator span, refer to Diagram 5.1. Proceed as follows:

- 5.1.2.1 With the system completely filled, adjust flow to its maximum value.
- 5.1.2.2 With power applied to the KAL-D, turn the setpoint potentiometer P1 clockwise to its far right-hand stop. The far right LED on the trend indicator will be flashing.
- 5.1.2.3 Momentarily depress the calibrating switch SW1 and release. The bi-colored LED will flash green for a brief period while the unit self-adjusts the span.

Note: Do not adjust the setpoint potentiometer P1 while the bi-colored LED is flashing. Doing this will invalidate the span adjustment and the procedure will have to be repeated.

- 5.1.2.4 When the bi-colored LED stops flashing, the span adjustment is complete. One measuring cycle after the bi-colored LED stops flashing (approximately 10 seconds) all, or nearly all eight of the trend indicator LEDs should be lit.

5.2 Flow Setpoint adjustment

To adjust the flow setpoint on the KAL-D, refer to Diagram 5.1. Proceed as follows:

- 5.2.0.1 Adjust system flow to the value at which the setpoint is desired.
- 5.2.0.2 Potentiometer P1 adjusts the flow setpoint. The flashing LED on the trend indicator signifies the switch point. You will notice that the flashing LED moves along the trend indicator scale as potentiometer P1 is adjusted.
- 5.2.0.3 With system flow adjusted to the desired value, adjust potentiometer P1 until the KAL-D output switches state and the bi-colored LED changes color.
- 5.2.0.4 The KAL-D flow setpoint is now adjusted and system flow can be restored to normal.

5.3 Switch Operation

The KAL-D is shipped from the factory as a normally open (N/O) or normally closed (N/C) logic, PNP or NPN transistor output based on the model purchased.

The characteristics of the switch logic, and the PNP and NPN transistor switch outputs are as follows:

N/O Switch:

System flow above the flow setpoint:	Switch = ACTIVATED Bi-colored LED = GREEN NPN Switch = Pin 4 SWITCHED TO GROUND PNP Switch = Pin 4 SWITCHED TO +24VDC
System flow below the flow setpoint:	Switch = DE-ACTIVATED Bi-colored LED = RED NPN Switch = Pin 4 HIGH RESISTANCE (open switch) PNP Switch = Pin 4 HIGH RESISTANCE (open switch)

N/C Switch:

System flow above the flow setpoint: Switch = **DE-ACTIVATED**
Bi-colored LED = **GREEN**
NPN Switch = **Pin 4 HIGH RESISTANCE (open switch)**
PNP Switch = **Pin 4 HIGH RESISTANCE (open switch)**

System flow below the flow setpoint: Switch = **ACTIVATED**
Bi-colored LED = **RED**
NPN Switch = **Pin 4 SWITCHED TO GROUND**
PNP Switch = **Pin 4 SWITCHED TO +24VDC**

5.4 KAL-D Diagnostics and Troubleshooting

The KAL-D continuously self-monitors the sensing probe and micro-processor systems. Any fault in these portions of the electronics will be signaled by a flashing red bi-colored LED and trend indicator. Additionally, if any of the calibrations (i.e. zero/span adjustments) are done improperly, the KAL-D bi-colored LED may flash red indicating that an error in the calibration procedure may have occurred. If the bi-colored LED starts to flash red at any time during the calibrating sequence, simply power the unit down for approximately 30 seconds, re-apply power and restart the calibration procedure. If the bi-colored LED flashes red during normal operation, a fault with the unit may have occurred. Contact KOBOLD Instruments for assistance.

6.0 Maintenance

The KAL-D thermal flow switch is an electronically controlled device with no moving parts. As a result, the unit is virtually maintenance free. Occasional cleaning of the immersed probe may be required if the fluid media is such that it tends to deposit or build up a film layer on the probe. If this occurs, the unit should be removed from the system any deposits or coatings on the probe should be removed.

7.0 Arrival of Damaged Equipment

Your instrument was inspected prior to shipment and found to be defect-free. If damage is visible on the unit, we advise that you carefully inspect the packing in which it was delivered. If damage is visible, notify your local carrier at once. The carrier is liable for a replacement under these circumstances. If your claim is refused, please contact KOBOLD Instruments.

8.0 Need Help With Your KAL-D

Call one of our friendly engineers at 412-788-2830

CAUTION

PLEASE READ THE FOLLOWING WARNINGS BEFORE ATTEMPTING
INSTALLATION OF YOUR NEW DEVICE. FAILURE TO HEED THE
INFORMATION HEREIN MAY RESULT IN EQUIPMENT FAILURE AND
POSSIBLE SUBSEQUENT PERSONAL INJURY.

- **User's Responsibility for Safety:** KOBOLD manufactures a wide range of process sensors and technologies. While each of these technologies are designed to operate in a wide variety of applications, it is the user's responsibility to select a technology that is appropriate for the application, to install it per these installation instructions, to perform tests of the installed system, and to maintain all components. The failure to do so could result in property damage or serious injury.
- **Proper Installation and Handling:** Use a proper sealant with all installations. Never overtighten the unit within the fitting. **Never use the housing to thread the unit into its fitting.** Always use only an appropriate sized wrench on the hex portion of the probe. Always check for leaks prior to system start-up.
- **Wiring and Electrical:** A supply voltage of 24 VDC $\pm 10\%$ is used to power the KAL-D. The sensor systems should never exceed this rating. Electrical wiring of the sensor should be performed in accordance with all applicable national, state, and local codes.
- **Temperature and Pressure:** The KAL-D is designed for use in application temperatures from -4 to 176°F , and for use at pressures up to 580 PSIG for threaded probes. Operation outside these limitations will cause damage to the unit and possible personal injury.
- **Material Compatibility:** The KAL-D sensor probe is made of 316L stainless steel. The housing is 304 stainless steel. Check your model number with the wetted materials specification in Section 2.0, "Specifications", on page 1 of this manual. Make sure that the model which you have selected is chemically compatible with the application liquids. While the switch housing is liquid resistant when installed properly, it is not designed to be immersed. It should be mounted in such a way that it does not normally come into contact with fluid.
- **Flammable, Explosive and Hazardous Applications:** The KAL-D series is not an explosion proof or intrinsically safe design. It should not be used in hazardous locations where an explosion proof or intrinsically safe design is required.
- **Make a Fail-Safe System:** Design a fail-safe system that accommodates the possibility of switch or power failure as well as operator error. In critical applications, KOBOLD recommends the use of redundant backup systems and alarms in addition to the primary system.