

SENTRY KW2000 Series

AutoPhase kW/kWh Transducers

The KW2000 Power Transducers provide an analog output signal proportional to power demand (kW), plus a pulsed output for totalizing energy consumption (kWh).



FEATURES

Accurate

Advanced microprocessor running at 5 MIPS provides high-speed sampling, true RMS calculations and meter grade digital accuracy (0.5% full scale).

Fast Installation

Patented AutoPhase Technology corrects common wiring errors such as CT reversal and phase mismatch, and can save hours of field labor.

Input Flexibility

Accepts ProteCT 0.333V safe CTs, eliminating the need for shorting blocks. Also accepts traditional 5A CTs. No separate potential transformers (voltage transformers) are required for monitoring up to 600VAC.

CONNECTIONS

1 ϕ Single Phase

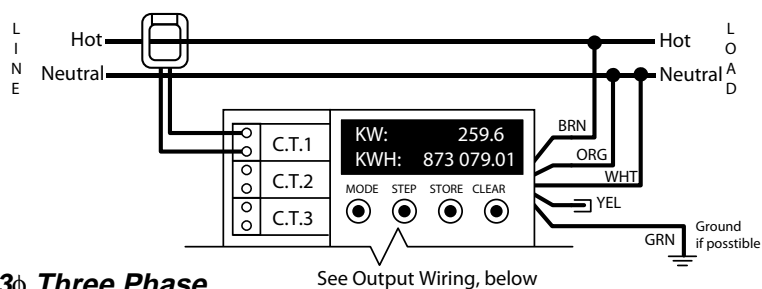

3 ϕ Three Phase

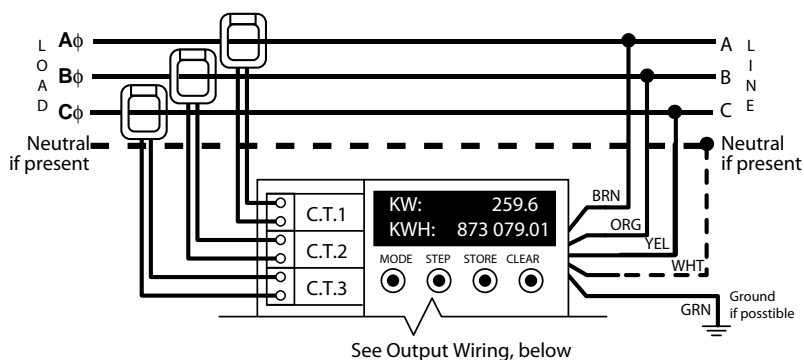

APPLICATIONS

- Energy management
- Facility and equipment power monitoring
- Sub-metering
- Performance contracting

Output Wiring

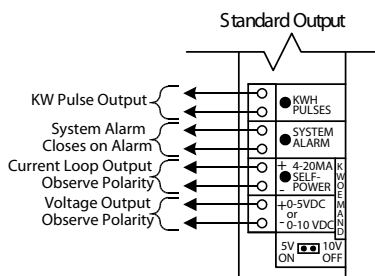

SENTRY KW2000

AutoPhase kW/k Wh Transducers

ORDERING INFORMATION

MODEL	HOUSING	CURRENT INPUT	PROGRAMMING	DISPLAY
Standard Output Models				
KW2013V	Module	ProteCT	Keypad	LCD
KW2113V	NEMA 1	ProteCT	Keypad	LCD
KW2213V	NEMA 1	ProteCT	Keypad on Module	LCD on Hinged Cover
KW2013A	Module	5A CT	Keypad	LCD
KW2113A	NEMA 1	5A CT	Keypad	LCD
KW2213A	NEMA 1	5A CT	Keypad on Module	LCD on Hinged Cover

SPECIFICATIONS

Power Requirement . . . None, powered from monitored line.
Accuracy 0.5% FS, True RMS power
Voltage Range 120,208,240,480 or 600 VAC autoranging.
Up to 35KV with optional potential transformers.
Inquire for 120V Network version.
Amperage Range 5-3000 Amps with ProteCT 0.333V CTs
50-3000 Amps with 5A output CTs
Frequency Range 50-60 Hz
Isolation Voltage 3,700 VAC
Built-in Fuse Rating . . . 600 VAC, 0.5A (no external fuses required)
Environmental 0-122°F (-18/50 °C), 0-95% RH, non-condensing
Dimensions Module: 9" H x 6.5 W x 2.6" D (23 x 16.5 x 6.5 cm)
NEMA1: 10" H x 10" W x 4" D (26 x 25 x 10 cm)
Connections Voltage: 12" leads, #18 AWG
Current Inputs
and All Outputs . . . Captive screw terminals accept 14-22 AWG wire
LCD Display Two lines, 16 characters

OUTPUTS, STANDARD MODELS

Analog Outputs Both available at all times (standard models)
kW 0-5 VDC or 0-10 VDC, user selectable,
self-powered, opto-isolated,
10 kΩ minimum load impedance
kW 4-20mA, self-powered 24VDC loop,
opto-isolated, 500Ω maximum load
Discrete Outputs Both available at all times (standard models)
System Alarm . . . Solid state N.O. contact, 100mA@30V AC/DC,
75, 80, 85, 95% under voltage set points
kWh Solid state contact, 100mA@30V AC/DC
Ranges: 0.01,0.1,1.0,10.0 kWh per pulse

Note: Please indicate CT values with order.

Authorized Distributor:
ControlSystemsUsa.com
Houston, TX USA
832-615-3588
sales@ControlSystemsUsa.com