

# TSSP Series

Load Cells for Bench Applications

**Specialty  
Single Point**



- 45 to 440 lb capacities available
- Moisture-proof barrier protection
- Stainless steel construction

Cardinal Scale's USA-made TSSP specialty single point series is a high performance and low cost load cell for use in bench scales, medical scales, and a variety of other applications. These low-profile load cells are constructed from high-grade (17-4) stainless steel and are easy to install. Available in capacities ranging from 45 to 440 lb / 20 to 200 kg, they feature integral mounting boss. All critical components and wiring are encapsulated to protect against moisture and to insure stable operation of the TSSP in harsh environments. OIML certified.

## MECHANICAL DATA

<b>Rated Capacity, (R.C.) E<sub>max</sub></b>	45 lb / 20 kg, 110 lb / 50 kg, 160 lb / 75 kg, 220 lb / 100 kg 440 lb / 200 kg (plus 200kg wide)
<b>Minimum Dead Load</b>	4.4 lb / 2 kg
<b>Safe Load Limit</b>	150% R.C.
<b>Ultimate Load</b>	300% R.C.
<b>Deflection at R.C.</b>	.008 in / 0.2 mm
<b>Net Weight</b>	1.97 lb / .9 kg

## CERTIFICATE DATA

<b>Issuing Body</b>	OIML
<b>Certificate Number</b>	R60/2000-NL1-04.20
<b>Accuracy Class</b>	C3
<b>Maximum Number of Load Cell Intervals, n<sub>max</sub></b>	3,000
<b>Single/Multiple</b>	S
<b>Minimum Load Cell Verification Interval V<sub>min</sub></b>	.1 oz / 2.8 g, .2 oz / 7 g, .3 oz / 10 g, 1 oz / 28 g

## ELECTRICAL DATA

<b>Rated Output</b>	2±0.1% mV/V
<b>Excitation Voltage, Minimum</b>	12 VDC
<b>Excitation Voltage, Maximum</b>	20 VDC
<b>Cable Length</b>	10 ft / 3 m
<b>Terminal Resistance</b>	
Excitation	435 ±10 ohms
Signal	350 ±5 ohms
<b>Zero Load Output</b>	±1% R.C.
<b>Insulation Resistance</b>	>5000 megohms at 50 VDC

## ENVIRONMENTAL DATA

<b>Temperature Compensation Range</b>	-10 to +40°C
<b>Operating Temperature Range</b>	-25 to +50°C
<b>Construction &amp; Protection Code</b>	IP65
<b>Barometric Pressure Effect on Zero Load Output</b>	<1 v (min)/1kPa

**MADE IN USA**

**TSSP**

LOAD CELL

# TSSP Series

**Specialty Single Point  
Load Cells for Bench Applications**

**Models Available:**  
**TSSP-20KG, TSSP-50KG**  
**TSSP-75KG, TSSP-100KG**  
**TSSP-200KG, TSSP-200KGW**

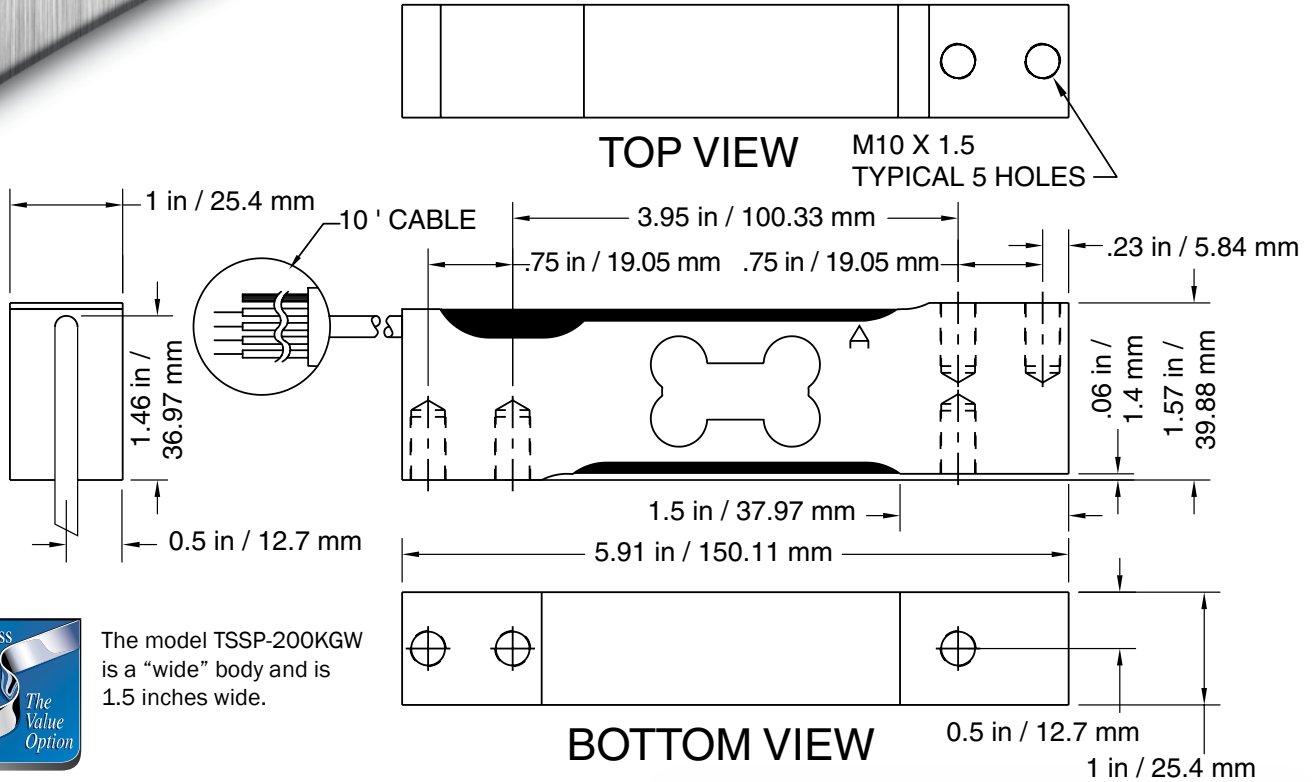

The model TSSP-200KGW is a "wide" body and is 1.5 inches wide.

### ELECTRICAL INFORMATION

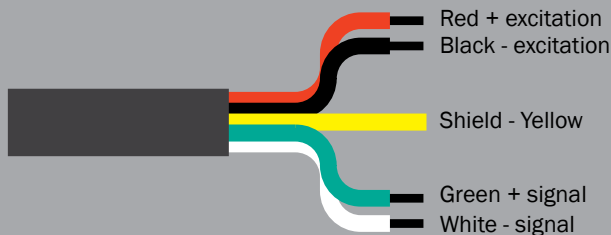

### State-of-the-Art Load Cell Manufacturing Facility ISO 9001 Quality Environment



### CERTIFICATIONS



Certificate of Conformance Number **R60/2000-NL1-04.20**

### VCAP CERTIFIED

Cardinal Scale has been formally audited and found to be fully compliant with the Verified Conformity Assessment Program (VCAP) administered by the National Type Evaluation Program (NTEP) of the National Conference on Weights and Measures (NCWM).

Cardinal Scale reserves the right to improve, enhance or modify features and specifications without prior notice. All registered trademarks are the property of their respective owners.

**Cardinal**  
 Cardinal Scale Manufacturing Co.  
 203 E. Daugerty, Webb City, MO 64870 USA  
 Ph: 417-673-4631 or 800-441-4237 • Fax: 417-673-5001  
[www.CardinalScale.com](http://www.CardinalScale.com)

### SOLD BY:

ControlSystemsUSA.com  
 Houston, Texas USA  
[sales@ControlSystemsUSA.com](mailto:sales@ControlSystemsUSA.com)  
 832-615-3588

