

DB Series

Double-ended Shear Beam, High-Capacity Load Cells



Cardinal Scale's USA-made heavy-capacity DB series double-ended shear beam load cells are ideal for multiple load cell applications such as vehicle scales and heavy-duty tank weighing systems. These load cells are fabricated from stainless steel to provide the ultimate in protection when caustic, corrosive or wet environments are encountered. They are environmentally-sealed for absolute water protection (IP68). Each load cell is furnished with a 50-ft/15-m integral multi-conductor cable secured by strain relief seal. 50,000 and 75,000 lb / 22,680 and 34,019 kg capacities.

- 50,000 and 75,000 lb capacities
- Environmentally-sealed (IP68)
- Stainless steel construction
- NTEP and OIML certified (DB75K not OIML)

MECHANICAL DATA

Rated Capacity, (R.C.) E _{max}	50,000 lb / 22,680 kg 75,000 lb / 34,019 kg
Minimum Dead Load	350 lb / 160 kg
Safe Load Limit	150% R.C.
Ultimate Load	300% R.C. DB-50000S 200% R.C. DB-75000S
Deflection at R.C.	.015 in / 0.38 mm
Net Weight	9 lb / 4 kg

CERTIFICATE DATA

Issuing Body	NTEP	OIML (DB50K only)
Certificate Number	97-133	R60/1991- DK-99.01
Accuracy Class	IIIL	C3
Maximum Number of Load Cell Intervals, n _{max}	10,000	3,000
Minimum Load Cell Verification Interval V _{min}	DB50K 1.4 lb DB75K 2.1 lb	2.5 kg 2.5 kg

ELECTRICAL DATA

Rated Output	2 ± 0.1% mV/V
Excitation Voltage, Maximum	15 VDC
Cable Length	50 ft / 15.2 m
Terminal Resistance	
Excitation	787 ± 40 ohms
Signal	702 ± 10 ohms
Zero Load Output	± 1% R.C.
Insulation Resistance	>5000 megohms at 50 VDC

ENVIRONMENTAL DATA

Temperature Compensation Range	-10° to +40°C
Operating Temperature Range	-29° to +93°C
Construction & Protection Code	CP-67 HU, IP68

LOAD CELL

MADE IN USA

DB

DB Series

High-Capacity, Double-Ended Shear Beam Load Cells

Model DB-50000S
Capacity: 50,000 lb/22,680 kg

Model DB-75000S
Capacity: 75,000 lb/34,019 kg

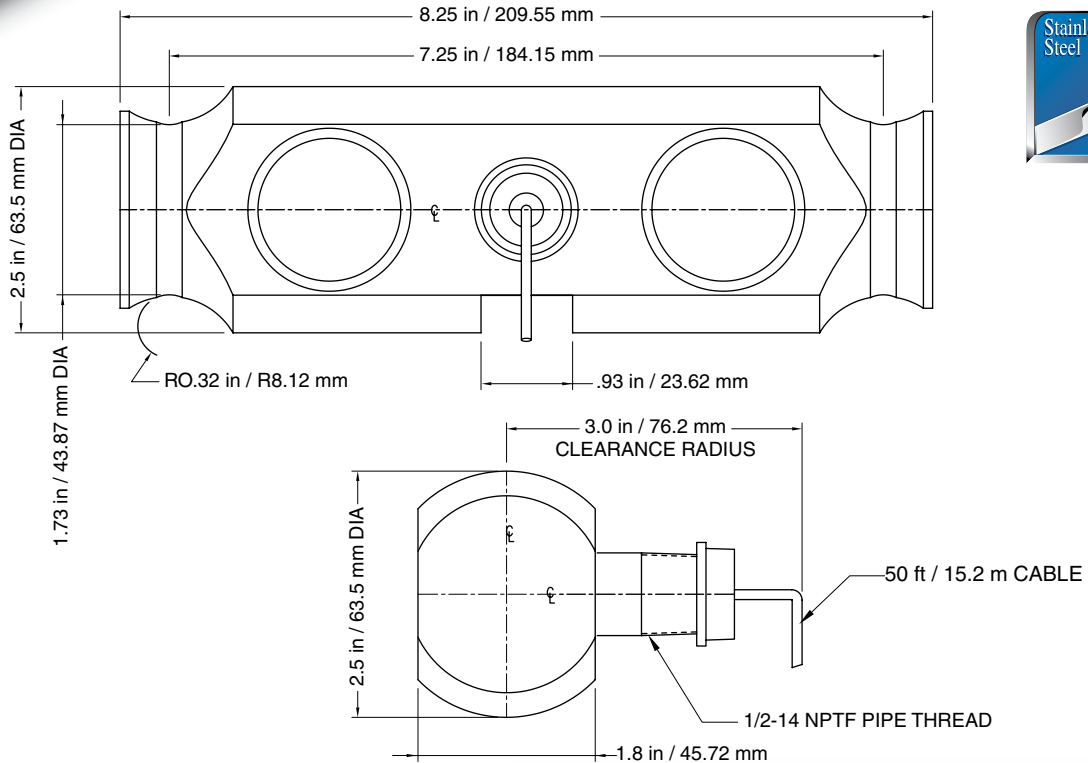

ELECTRICAL INFORMATION

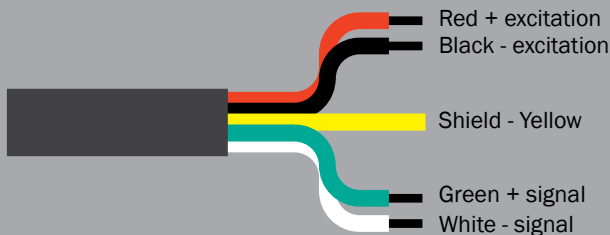

State-of-the-Art Load Cell Manufacturing Facility ISO 9001 Quality Environment



CERTIFICATIONS



The DB-50000S load cell meets all requirements of OIML R60 and has been issued OIML Certificate No. **R60/1991-DK-99.01**



The DB-50000S and DB-75000S load cells meet all requirements of Handbook 44, issued by the National Institute of Standards and Technology and have been issued the NTEP Certificate of Conformance No. **97-133**.

VCAP CERTIFIED

Cardinal Scale has been formally audited and found to be fully compliant with the Verified Conformity Assessment Program (VCAP) administered by the National Type Evaluation Program (NTEP) of the National Conference on Weights and Measures (NCWM).

Cardinal Scale reserves the right to improve, enhance or modify features and specifications without prior notice. All registered trademarks are the property of their respective owners.

Cardinal
Cardinal Scale Manufacturing Co.
203 E. Daugherty, Webb City, MO 64870 USA
Ph: 417-673-4631 or 800-441-4237 • Fax: 417-673-5001
www.CardinalScale.com

SOLD BY:

ControlSystemsUSA.com
Houston, Texas USA
sales@ControlSystemsUSA.com
832-615-3588

