

## Compact Thermal Flow Switch

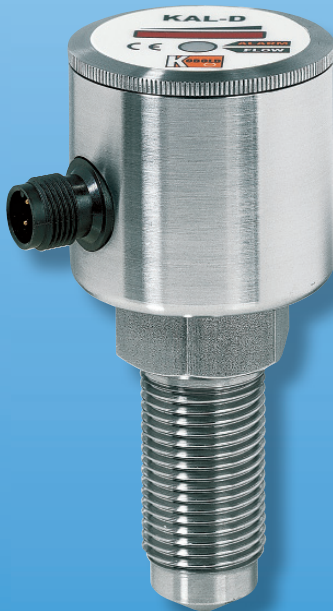

measuring  
•  
monitoring  
•  
analyzing

KAL-D



- No Moving Parts
- Switching Range 0.15...6.6 Ft/Sec.
- Max. Pressure 580 PSIG
- Max. Operating Temperature 176 °F
- Clean-In-Place to 250 °F



KOBOLD companies worldwide:

ARGENTINA, AUSTRIA, BELGIUM, BULGARIA, CANADA, CHILE, CHINA, COLOMBIA, CZECH REPUBLIC, EGYPT, FRANCE, GERMANY, GREAT BRITAIN, HUNGARY, INDIA, INDONESIA, ITALY, MALAYSIA, MEXICO, NETHERLANDS, PERU, POLAND, ROMANIA, SINGAPORE, SOUTH KOREA, SPAIN, SWITZERLAND, TAIWAN, THAILAND, TUNISIA, TURKEY, USA, VIETNAM

Authorized Distributor:  
ControlSystemsUsa.com  
Houston, TX USA  
832-615-3588  
sales@ControlSystemsUsa.com



**Description**

The KAL-D series combines the features of our legendary KAL-K thermal flow switch with a compact size. The KAL-D uses the calorimetric principle to monitor the flowrate of non-viscous water-based liquids. The sensor tip is heated to a few degrees above the liquid temperature. As the liquid flows across the tip, it is cooled by the liquid. The amount of cooling is proportional to liquid velocity. The liquid velocity is compared to the setpoint which is field-adjustable by the user. A transistor switch is activated when the flow setpoint is reached. The KAL-D series has a smooth measuring probe with no moving parts making it exceptionally reliable and insensitive to dirt and solids. The insertion type probe allows for flow monitoring with minimal system pressure loss.



**Microprocessor-Based Temperature Compensation**

The KAL-D series achieves superior compensation for changes in liquid temperature during the measuring cycle by use of a microcontroller. This method of temperature compensation allows for very precise correction of flow measurement when liquid temperature changes occur.

**Specifications**

- Applications:** Non-viscous, water-based liquids
- Switching Range:** 0.15...6.6 Ft/Sec.
- Repeatability:** ±2%
- Response Time:** 5.6...12 seconds typical
- Switch Point Adjustment:** Via potentiometer  
Flashing LED indicates setpoint on 8 LED bargraph indicator
- Status Indicator:** 1 dual color LED
- Maximum Pressure:** 580 PSIG
- Operating Temperature Range:** -4...176 °F
- Max. Clean-in-Place Temperature:** 250 °F
- Wetted Parts:** 316L SS
- Housing Material:** 304 SS
- Power Requirements:** 24 V<sub>DC</sub> ± 10% at 150 mA Max.
- Switch Type:** NPN or PNP open collector, normally open or normally closed based on ordering code
- Switch Rating:** 400 mA Max. at 24 V<sub>DC</sub>, short circuit protected
- Electrical Connection:** Micro DC plug, 4-pin male
- Electrical Protection:** NEMA 4/IP65

**Measuring/Switch Ranges**

Pipe Diameter	Approximate Switching Range (GPM)	Pipe Diameter	Approximate Switching Range (GPM)
1/4"	0.02...1.0	1 1/2"	0.75...35
1/2"	0.1...4.0	2"	1.3...60
3/4"	0.2...9.0	3"	3...140
1"	0.3...15	4"	5.2...250
1 1/4"	0.5...25	6"	12...575

**Important:**

The flow ranges specified in the table above have been calculated for each pipe diameter based upon the design velocity range of the KAL-D. It must be noted that flow in pipes is non-uniform across the pipe cross section and approaches zero at the pipe wall. This means that, in practice, the installation depth of the probe, the internal pipe diameter, and the flow profile of the liquid in the pipe, can interact to produce VERY significant deviations from the flow ranges in the above table.

**Order Details** (Example: KAL-D5408 N ST3)

Fitting Type	Model Number	Type of Switch	Connector
1/4" NPT	KAL-D5408	..N.. = NPN, N/O ..P.. = PNP, N/O ..M.. = NPN, N/C ..R.. = PNP, N/C	..ST3 = Micro-DC plug, 4-Pin, male
1/2" NPT	KAL-D5415		
M12x1	KAL-D0412		
1/4" BSP	KAL-D1408		
1/2" BSP	KAL-D1415		

**Accessory:**  
807.037 = Mating 4-pin Micro-DC plug with 6 foot cable

**KAL Timing - Heating and Measuring Cycle**

**Typical Flow Measuring Cycle**

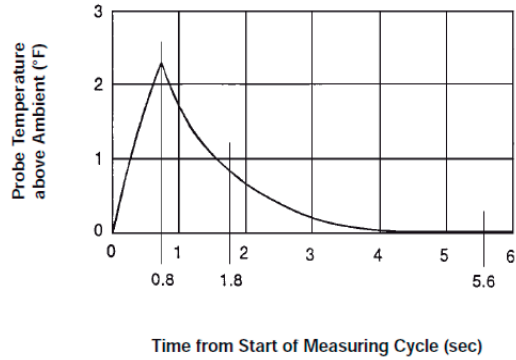

**Operating Behavior**

1. At t=0, the probe temperature is recorded. This reading represents the ambient liquid temperature.
2. Still at t=0, the KAL begins heating the probe.
3. At t=0.8 seconds, the heating cycle ends and the KAL begins monitoring the probe temperature.
4. At t=1.8 seconds, a temperature reading is taken and compared to the t=0.8 second temperature. The rate of cooling is calculated and compared to a Cooling Rate vs Flow Rate table specific to the ambient temperature recorded at t=0.
5. The probe is allowed to cool until t=5.6 seconds. A temperature reading is taken and compared to the initial t=0 reading. If the temperatures are equal (or nearly so), the flow reading is determined valid and passes through to the KAL output. If the temperatures are not equal, the KAL waits another 5.6 sec, and Step 5 repeats.

**Dimensions (mm)**

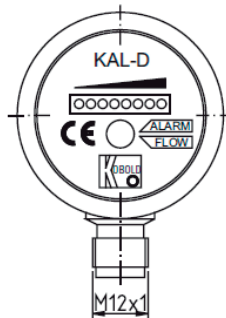
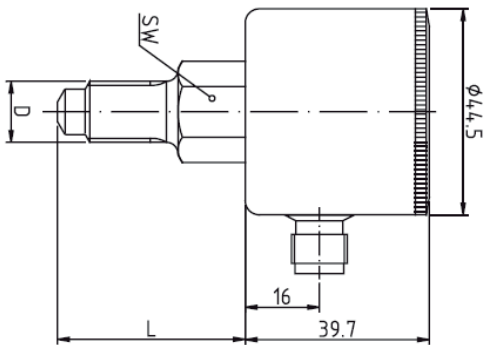

D	L	SW
1/4" NPT	1.6"	19 mm
1/2" NPT	2.2"	27 mm
M12x1	1.6"	19 mm
1/4" BSP	1.6"	19 mm
1/2" BSP	2.2"	27 mm