

Signet 8900 Multi-Parameter Controller



3-8900.090-1 Rev. K 01/13 English



Contents

1. Specifications	2	9. Channel Settings	24
2. Description	4	9.1 Channel Settings: Flow	24
2.1 Compatibility	4	9.2 Channel Settings: pH	25
2.2 System Overview	5	9.3 Channel Settings: ORP	25
3. Installation and Basic Functionality	6	9.4 Channel Settings: Conductivity	26
3.1 Unpacking	6	9.5 Channel Settings: Pressure	27
3.2 Tools and Equipment Required	6	9.6 Channel Settings: Temperature	27
4. Plug-in Modules	6	9.7 Channel Settings: Level	28
4.1 I/O Module	7	9.8 Channel Settings: OTHER (4–20)	30
4.2 Power Module	7	10. Hold Inputs	30
4.3 Output Module	8	11. Relay Mode Descriptions	31
4.4 Relay Module	8	11.1 Relay Setup Menu	33
4.5 8059 External Relay Module	9	11.2 Advanced Relay Mode	34
5. Mounting the Base Unit	10	12. Output	35
5.1 Panel Mounting	10	13. Calibration	36
5.2 Mounting Accessories	11	13.1 Calibration: Flow	36
6. Wiring	12	13.2 Calibration: pH	37
6.1 Signal Type: Frequency	12	13.3 Calibration: ORP	37
6.2 Digital (S ³ L) Input wiring	13	13.4 Calibration: Conductivity	38
6.2.1 Digital Cable Length Calculations	14	13.5 Calibration: Pressure	38
6.2.2 Digital Cable Routing Diagrams	15	13.6 Calibration: Temperature	38
6.3 Power Module (3-8900.402-X)	17	13.7 Calibration: Level	38
6.4 Output Module (3-8900.405-X)	17	14. Options	39
6.5 Relay Module (3-8900.403-X)	18	14.1 Password Security	39
6.6 8059 External Relay Module	18	Appendix A: Derived Functions	40
7. Operational Overview	19	Appendix B: Level System Configuration	41
7.1 General Operation Flowchart	19	Appendix C: Conductivity & Temp Comp	43
7.2 System Configuration	20	Appendix D: USP Limits	44
7.3 Menu Directory	20	Appendix E: Cloning using Digital (S³L)	45
8. System Setup Menu	21	Appendix F: BTU Quick Start Guide	47
8.1 System Setup: Channel Type	21	Appendix G: 8900 display messages	48
8.2 Automatic Sensor Recognition	22	Ordering Information	52
8.3 Automatic Channel Assignment	22	AUTHORIZED DISTRIBUTOR:	
8.4 Automatic Display Configurations	22	ControlSystemsUSA.com	
8.5 Other Automatic Displays	23	Houston, Texas USA	
8.6 Displays for Derived Functions	23	sales@ControlSystemsUSA.com	
		832-615-3588	

Important Safety Information

- Read and understand instruction manual before using this product.
- This unit is designed to be connected to equipment which can be hazardous to persons and property if used incorrectly. Read and understand all associated equipment manuals and safety warnings before using with this product.
- Do not remove rear panel slot shields if the modules are not installed.
- Remove power to unit before wiring input and output connections.
- Wiring connections to this product should only be performed by qualified personnel.
- Do not exceed published specifications in the use of this product.
- In case of communication error or loss of source signal:
 - Relays will be deactivated.
 - Current outputs will go to 22.1 mA.
 - Voltage outputs will go to 0 V.

1. Specifications

General

Number of input channels: 2 or 4 or 6

Input signal types:

Digital (S³L): Serial ASCII, TTL level 9600 bps
 Frequency: Range: 0 to 1500 Hz
 Accuracy: 0.5% of reading

Measurement types: Flow, pH, ORP, Conductivity/
 Resistivity, Pressure, Temperature,
 Level or user-defined (via 8058)

Derived measurements: Sum, Difference, Ratio, % Recovery,
 % Reject, % Passage, Power

Number of relays: 8 Maximum
 (max 8 Dry-contact, max 4 Solid State)

Number of analog outputs: (4) 4 to 20 mA (active and/or passive);
 and/or (2) 0 to 5/10 VDC

Enclosure and Display

Case Material: PBT
 Panel Gasket: Silicone Sponge
 Window: Self-healing polyurethane-coated polycarbonate
 Keypad: 4 buttons
 Display: Injection-molded silicone rubber seal
 Alphanumeric 2 x 16 Back-lit LCD
 Update rate: 1 s
 LCD Contrast: 4 settings

Display ranges:

pH: 0.00 pH to 15.00 pH
 pH Temp.: -40 °C to 150 °C (-40 °F to 302 °F)
 ORP: -9999 to +9999 mV
 Flow Rate: 0.0000 to 999999 units per second, minute, hour or day
 Totalizer: 0.00 to 99999999 units
 Conductivity: 0.0000 to 999999 µS, mS, PPM & PPB (TDS), kΩ, MΩ
 Cond. Temp.: -99.9 °C to 250 °C (-148 °F to 482 °F)
 Temperature: -99.9 °C to 999.9 °C (-148 °F to 999.9 °F)
 Pressure: -99.99 to 9999 psi, kPa, bar
 Level: -99999 to 99999 m, cm, ft, in, %
 Volume: -99999 to 999999 cm³, m³, in³, ft³, gal, L, lb, kg, %

Dimensions

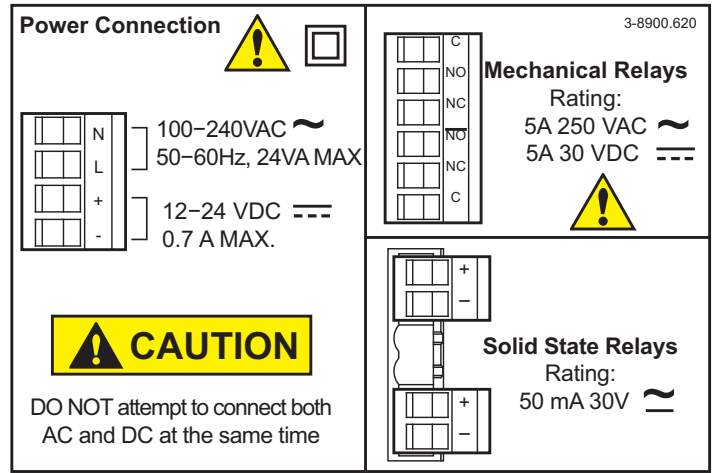
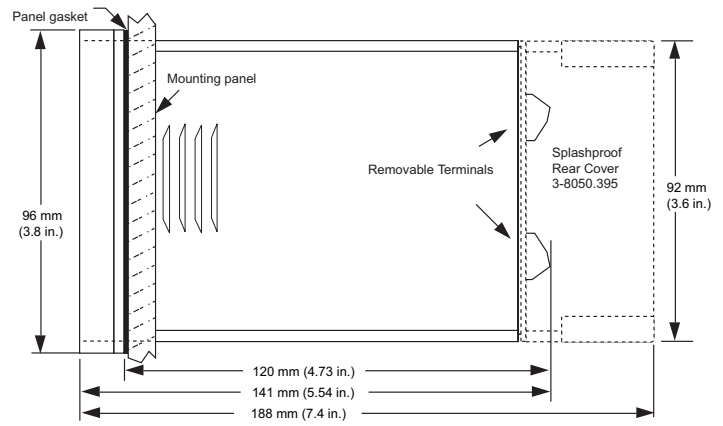

Electrical

Power Requirements (AC or DC Power Modules)

Universal AC: 100 to 240 VAC ±10%, regulated 50–60 Hz, 24 VA max.

DC: 12 to 24 VDC ±10%, regulated recommended, 7 watts max.

Output Power to Sensors:

5VDC @ 40 mA (to 90 mA under special conditions; see digital (S³L) wiring info)

Terminal type: Screw clamp, removable via plug-in modules

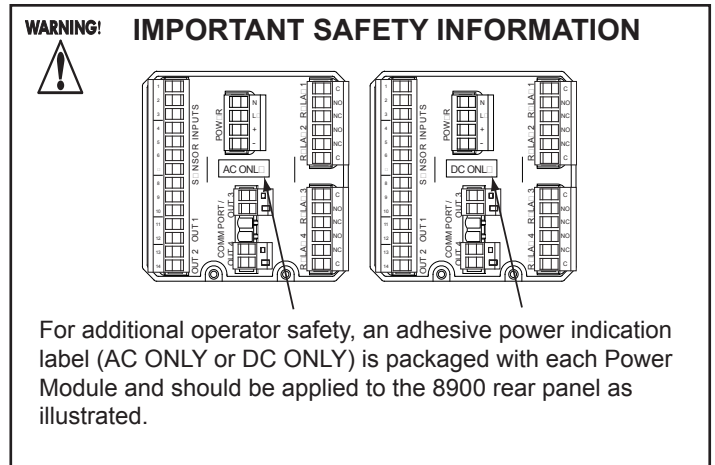

Analog Outputs (via I/O Modules and Output Modules)

4 to 20 mA Output:

Endpoints are adjustable and reversible:

Minimum:	4.0 mA; adjustable from 3.8 to 5.0 mA
Maximum:	20.00 mA; adjustable from 19.0 to 21.0 mA
Test mode:	Produces an adjustable 4 to 20 mA signal for functional verification of each output circuit
Isolation:	Up to 48 V AC/DC
Error condition:	22.1 mA (default state if output source not configured)
Update rate:	100 mS
Accuracy:	±32 µA over entire operating temperature range
Resolution:	6 µA
Power Rejection:	±1 µA/V Short circuit and reverse polarity protected

Passive 4 to 20 mA:

Voltage Required:	12 to 24 VDC ± 10%
Max. Impedance:	250 Ω @ 12 VDC 500 Ω @ 18 VDC 750 Ω @ 24 VDC

Active 4 to 20 mA:

Max Impedance:	650 Ω
----------------	-------

0 to 5/10 VDC Output:

Output range:	0 to 5 VDC or 0 to 10 VDC, software selectable Endpoints are adjustable and reversible:
Min. default:	0 VDC; programmable from 0 to 0.5 VDC
Max. default:	5 VDC; programmable from 4.5 to 5.5 VDC, or 9.5 to 10.5 VDC
Output load:	10 kΩ minimum
Test mode:	Produces an adjustable signal for functional verification of each output circuit
Isolation:	Up to 48 V AC/DC
Error condition:	0 VDC (default state if output source not configured)
Update rate:	100 mS
Accuracy:	±20 mV over operating temperature range
Resolution:	5 mV
Power Rejection:	0.5 mV/V

Environmental Requirements

Ambient operating temperature:	
Back-lit LCD:	-10 °C to 55 °C (14 °F to 131 °F)
Storage Temp.:	-15 °C to 80 °C (5 °F to 176 °F)
Relative Humidity:	0 to 95%, non-condensing
Maximum Altitude:	2,000m (6,560 ft) 4,000m (13,123 ft); use only DC power supply and, if applicable, solid state relays to maintain UL safety standard up to this altitude
Enclosure Rating:	NEMA 4X/IP65 (front face only)

Relay Modules

Modes of operation:	
Internal Relays:	Off, Low, High, Window, Vol. Pulse, Prop. Pulse, Pulse Width Modulation, Total Volume, USP, Advanced
External relays:	Off, Low, High, Window, USP Total Volume, Advanced
Hysteresis:	User adjustable
Time Delay:	0 to 6400 seconds

Solid State Relays

Normally open/closed operation:

	Software selectable
Maximum pulse rate:	
Volumetric Pulse:	600 pulses per minute
Pulse Width Modulation:	600 pulses per minute
Proportional Pulse:	400 pulses per minute
Max. voltage rating:	30 VDC or 42 VAC p-p
Current rating:	50 mA DC or 50 mA AC RMS
On-state impedance:	30 ohms or less
Off-state leakage:	400 nA or less, AC or DC
Isolation:	Up to 48 V AC/DC
Transient protection:	Embedded, up to 48 V over-voltage

Dry-contact Relays

Type:	SPDT
Form:	C
Maximum pulse rate:	
Volumetric Pulse:	600 pulses per minute
Pulse Width Modulation:	600 pulses per minute
Proportional Pulse:	400 pulses per minute
Max. voltage rating:	30 VDC or 250 VAC
Current rating:	5 A

Standards and Approvals

CE
UL
Manufactured under ISO 9001 for Quality, ISO 14001 for Environmental Management and OHSAS 18001 for Occupational Health and Safety.

FC Declaration of Conformity according to FCC Part 15
This device complies with Part 15 of the FCC rules. Operation is subject to the following two conditions:
(1) This device may not cause harmful interference, and,
(2) This device must accept any interference received, including interference that may cause undesired operation.

 China RoHS (Go to www.gfsignet.com for details)

Shipping Weights

Base Unit	1.00 kg (2.25 lb.)
Power Module	0.12 kg (0.25 lb.)
I/O Module	0.12 kg (0.25 lb.)
Output Module	0.12 kg (0.25 lb.)
Relay Module	0.12 kg (0.25 lb.)

2. Description

The 8900 Multi-Parameter Controller takes the concept of modularity to the extreme. The controller comes with backlit display that provides clear visibility in dark environments. In addition, ultimate flexibility is achieved via plug-in modules for two, four or six input channels, universal AC line voltage or 12 to 24 VDC power, up to four analog outputs, and up to four relays. The controller will support up to four additional relays, for a total of eight, by way of external relay modules.











Absolute input versatility allows mixing and matching of up to six sensors with digital (S³L) output. Up to two of the possible six input channels may be used for Signet flow sensors with frequency output. The 8058 Signal Converter module enables any 4 to 20 mA signal to be used as input to the 8900.

2.1 Compatibility





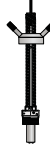
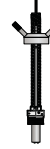

Model numbers of sensors and external relays compatible with the 8900 are identified in the tables below.

- For two channel systems, mix and match up to two of any of these sensors.
- For four channel systems, mix and match up to four sensors with digital (S³L) output.
- For Six channel systems, mix and match up to six sensors with digital (S³L) output.
- The optional external relays connect via digital (S³L) to the I/O Module, but do NOT consume a sensor input channel.
- pH and conductivity sensors include temperature sensors. These "secondary" measurements are treated by the 8900 as separate sensors with respect to display, output and relay functionality, but they do NOT consume separate input channels.

Flow Sensors

Paddlewheels					Turbine, Mini & Micro Flow			Insertion Magmeters			
515	525	2536	2537	2540	2100	2000	2507	2551	2551	2552	2552
Freq.	Freq.	Freq.	digital (S ³ L)	Freq.	Freq.	Freq.	Freq.	Freq.	digital (S ³ L)	Freq.	digital (S ³ L)
											

Analytical Sensors

pH & ORP Sensors	Cond/Res Sensors	Pressure Sensors	Level Sensors	Temp. Sensors	Other Accessories	
2750 Sensor Electronics with DryLoc pH Electrodes	2850 Sensor Electronics with DryLoc Conductivity Electrodes	2450 Pressure Sensors	2250 Level Sensors	2350 Temperature Sensors	8058 4 to 20 mA Signal Converter	8059 External Relay Modules
digital (S ³ L)	digital (S ³ L)	digital (S ³ L)	digital (S ³ L)	digital (S ³ L)	digital (S ³ L)	digital (S ³ L)
						

2.2 System Overview

The most basic 8900 system consists of a Base Unit, an I/O Module and a Power Module. Outputs and relays are optional. Each item is ordered separately. See Section 3 Installation & Basic Functionality, and Ordering Information for more details.

- a. Base Unit, required.
- b. Rear panel shown installed with shields in place for the optional modules. No plug-in modules are installed in this view.
- c. Slot for the required I/O Module. Choose one (1) for either two or four or six input channels. This module is also used for optional Analog Outputs 1 & 2.
- d. Slot for the required Power Module. Choose one (1) to power the unit with either universal AC line voltage or 12 to 24 VDC.
- e. Slot for an optional Output Module. Choose Analog Outputs 3 & 4 or neither.
- f. Slot for an optional Relay Module. Choose Relays 1 & 2, or not.
- g. Slot for another optional Relay Module. Choose Relays 3 & 4, or not.
- h. External Relay Modules connect via digital (S³L) to the I/O Module and are optional.
- i. Plug-in modules slide into the base unit on rails and are then held securely in place by the rear panel. Changes and upgrades can be made in the field at any time.

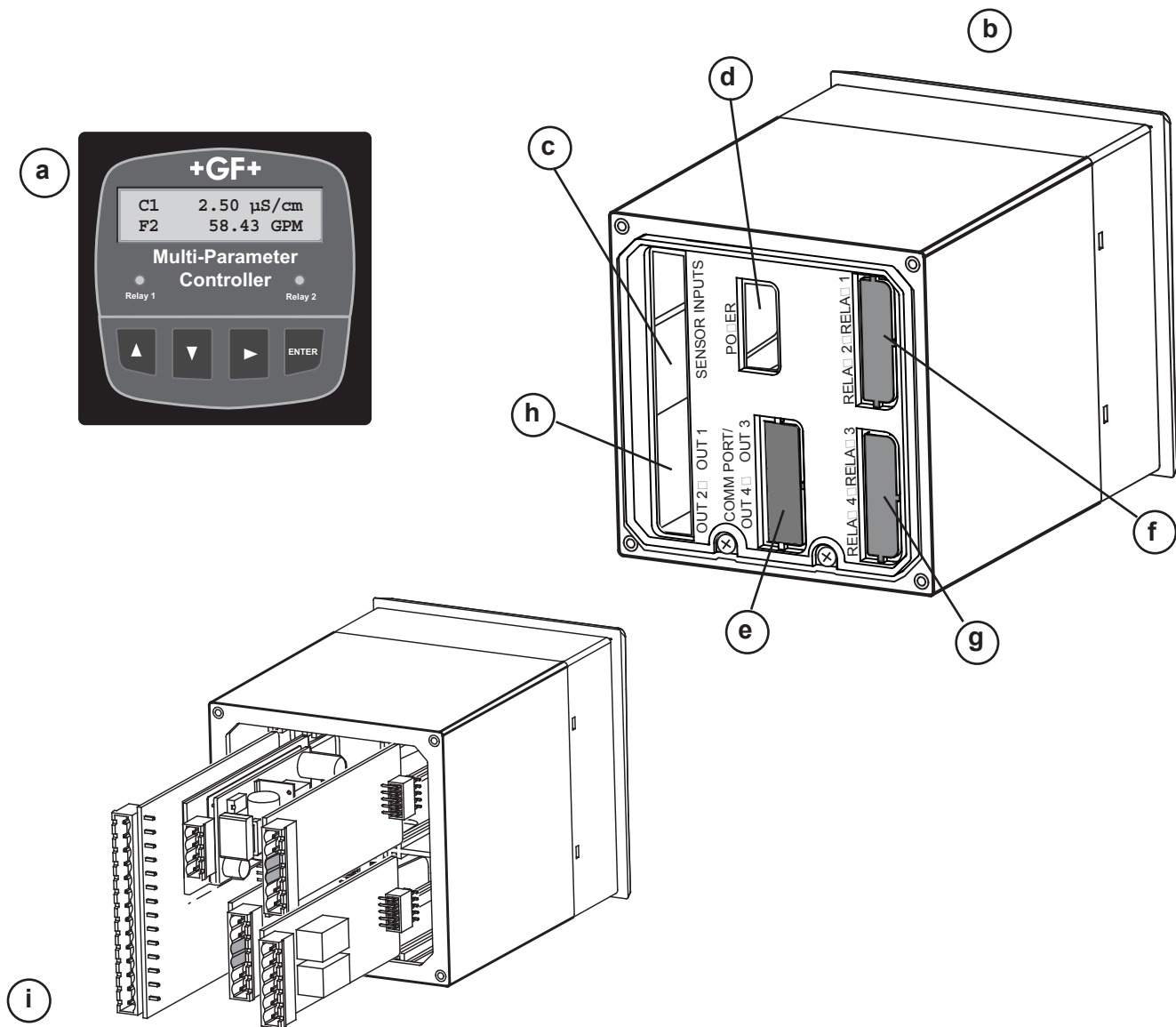

3. Installation and Basic Functionality

This section lists all items included with individual 8900 system components, describes installation detail for plug-in modules and base units, and provides information and instruction on the basic functionality of the plug-in modules.

3.1 Unpacking

Base units, plug-in modules, accessories and spare parts are sold, packaged and shipped separately from the factory. Unpack all components carefully. The following items accompany every 8900 base unit:

- 8900 Base Unit with a backlit LCD
- Front Face Panel Gasket (pre-installed on base unit)
- Quick-clip panel mounting bracket
- Adhesive Template for panel cutout
- Instruction Manual, Paper copy – English
- CD-ROM containing instruction manuals in English, French, German, Spanish, Italian and Portuguese

For future reference, for each installation, it is recommended to record the part number and serial number of each of the components listed here:

Facility Tag Number or System ID (user assigned): _____

Base unit	3-8900- _____ S/N _____	Relay Module	3-8900.403- _____ S/N _____
I/O Module	3-8900.401- _____ S/N _____	Relay Module	3-8900.403- _____ S/N _____
Power Module	3-8900.402- _____ S/N _____	Ext Relay Module	3-8059- _____ S/N _____
		Output Module	3-8900.405- _____ S/N _____

3.2 Tools and Equipment Required:

- Phillips screwdriver (medium tip)
- Standard screwdriver (small/medium tip)
- Diagonal cutters (small)
- File (fine)
- ¼-DIN punch or jigsaw suitable for cutting panel opening to within 1 mm (0.020 in.) tolerance.

4. Plug-in Modules

- If the 8900 Base Unit will be mounted in a panel, plug-in modules may be installed either before or after the base unit is mounted. If the 8900 Base Unit will be mounted using the accessory Wall Mount Bracket, first install plug-in modules.
- Plug-in modules are packaged in anti-static bags and contain individual instruction sheets and removable terminals for convenient wiring. Minimize handling of plug-in modules to reduce the probability of damage due to static discharge.
- Power Modules include adhesive labels to be applied to the outside of the 8900 enclosure in specific locations as illustrated in **section 4.2**.
- The rear panel of the 8900 must be removed prior to installing or removing plug-in modules. If plug-in modules are already installed, the terminals must be removed prior to removing the rear panel. It may be helpful to use a standard screwdriver to gently pry removable terminals away from the receptacle on the plug-in modules.
- Use a Phillips screwdriver to loosen the two captive screws at the bottom of the panel. Pinch one of the screws and **swing the panel up approximately 90°**, using the tab hinge at the top of the panel, and pull it straight away from the base unit. Reverse this step to reinstall the panel after the plug-in modules are installed.

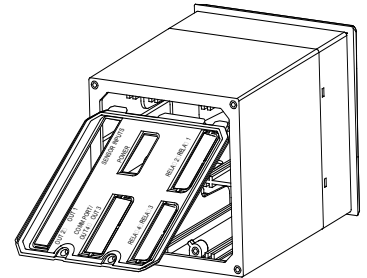

- Remove terminals from the receptacle of each plug-in module prior to installation.
- Use diagonal cutters to remove slot shields from the rear panel for optional plug-in modules as required. Only remove shields for slots to be used (UL safety requirement).
- Smooth any protruding edges with a file.
- Reinstall the rear panel; it will hold the modules securely in place.

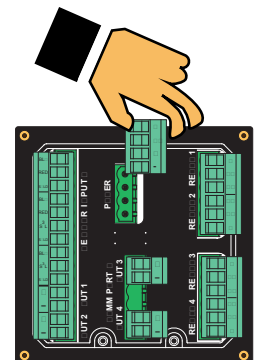

4.1 I/O Module, required; install one (1)

Mfr. Part No.	Description
3-8900.401-1	Two inputs, no outputs
3-8900.401-2	Two inputs, two passive 4 to 20 mA outputs
3-8900.401-3	Two inputs, two active 4 to 20 mA outputs
3-8900.401-4	Two inputs, two 0 to 5/10 VDC outputs
3-8900.401-5	Four inputs, no outputs
3-8900.401-6	Four inputs, two passive 4 to 20 mA outputs
3-8900.401-7	Four inputs, two active 4 to 20 mA outputs
3-8900.401-8	Four inputs, two 0 to 5/10 VDC outputs
3-8900.401-9	Six inputs, no outputs
3-8900.401-10	Six inputs, two passive 4 to 20 mA outputs
3-8900.401-11	Six inputs, two active 4 to 20 mA outputs
3-8900.401-12	Six inputs, two 0 to 5/10 VDC outputs

- These modules determine the maximum number of sensor input channels available for the instrument. The 8900 will detect all connected sensors at startup and assign channels up to the maximum available on the I/O Module.
- Optional analog outputs are contained on the I/O Module, and will always be identified as Outputs 1 & 2 in the 8900 menus. Any and all analog outputs are freely assignable to any channel. All analog outputs available from the 8900 are isolated.
- Voltage outputs are independently software selectable for operation from 0 to 5 or 0 to 10 VDC.

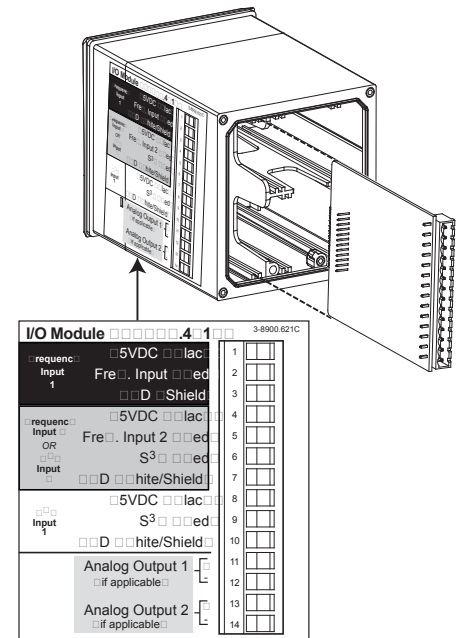

4.2 Power Module, required; install one (1)

Mfr. Part No.	Description
3-8900.402-1	85 to 264 VAC, 50/60 Hz
3-8900.402-2	12 to 24 VDC ±10%

- Each 8900 Base Unit may be powered with either AC or DC voltage, but not both simultaneously (no "uninterruptible" power option).
- The AC Power Module is universal; no jumper selection is required.

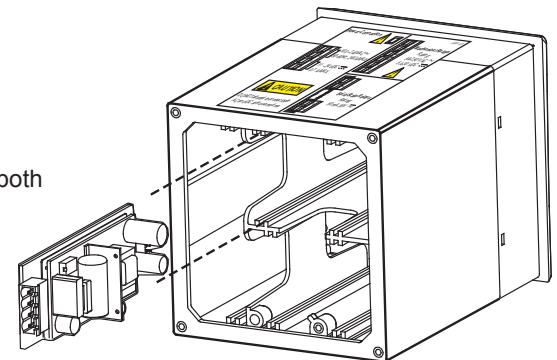

IMPORTANT SAFETY INFORMATION

For additional operator safety, an adhesive power indication label (**AC ONLY** or **DC ONLY**) is packaged with each Power Module and should be applied to the 8900 rear panel as illustrated.

4.3 Output Module, optional; install zero (0) or one (1)

Mfr. Part No.	Description
3-8900.405-1	Two passive 4 to 20 mA outputs
3-8900.405-2	Two active 4 to 20 mA outputs

- Optional analog Outputs 1 & 2 are obtained via the I/O Module, but are not required to be installed in order to use the optional analog output modules listed immediately above.
- The analog outputs obtained via these separate modules will always be identified as Outputs 3 & 4 in the 8900 menus. The slot on the rear panel is labeled accordingly.
- It is perfectly acceptable to mix and match analog output types between those contained on the I/O Module and those obtained via these separate modules.
- Any and all analog outputs are freely assignable to any channel.
- All analog outputs available from the 8900 are isolated.
- Passive outputs throttle current in loops powered by a supply external to the 8900.
- Active outputs throttle current in loops powered by the 8900; no external power source is required.

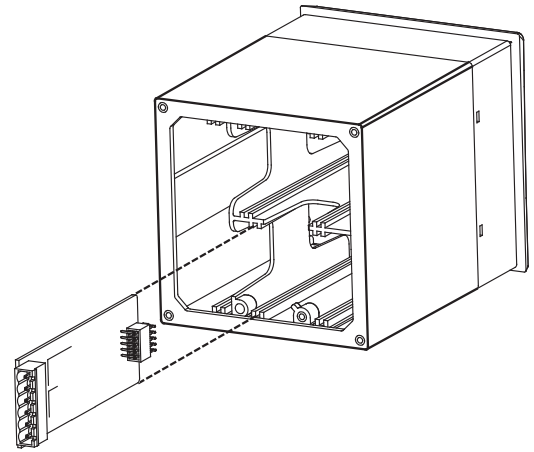





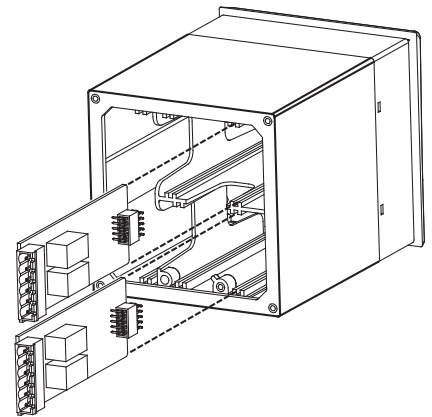

4.4 Relay Module, optional; install zero (0), one (1) or two (2)

Mfr. Part No.	Description
3-8900.403-1	Two dry-contact relays
3-8900.403-2	Two solid-state relays
3-8050.396	RC Filter Kit

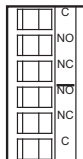
- Up to two sets of two relays may be installed directly into the 8900. The modules are completely independent of one another, so it is not necessary for Relays 1 & 2 to be installed in order to use Relays 3 & 4.
- However, in accordance with the labeling on the rear panel, relays installed directly into the 8900 via these plug-in modules will always be identified in the 8900 menus as Relays 1 & 2 and 3 & 4, respectively.
- The red LED relay status indicators on the front panel of the 8900 are hardwired to Relays 1 & 2. If the slot for Relays 1 & 2 is vacant, the red LEDs will be inoperative. Status of all relays is available at all times in a single screen in View mode.
- It is perfectly acceptable to mix and match the relay types installed directly in the 8900, as well as between internal and external modules.
- Any and all relays are freely assignable to any channel. Hysteresis and time delay are adjustable for each relay.
- Dry-contact relays are electromechanical switches with a moving contact armature. They are suitable for many general-purpose applications, AC or DC, including AC loads up to 250 V.
- Solid-state relays are electronic switches with no moving parts. They may be used with AC or DC loads, but have lower current handling capability and voltage ratings than Dry-contact relays. Solid-state relays will outlast Dry-contact relays in pulsing applications.
- Switching active loads (most commonly inductive) can cause contact arcing sufficient to damage both types of relays. The RC Filter Kit or "snubber" is available as an accessory to reduce or eliminate these damaging effects.

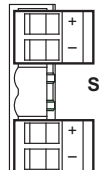

Power Connection 		<small>3-8900.620</small>	
	100-240VAC ~ 50-60Hz, 24VA MAX		Mechanical Relays Rating: 5A 250 VAC ~ 5A 30 VDC ---
	12-24 VDC --- 0.7 A MAX.		
 CAUTION			Solid State Relays Rating: 50 mA 30V ~
DO NOT attempt to connect both AC and DC at the same time			

4.5 8059 External Relay Module, optional; install zero (0) or one (1)

Mfr. Part No.	Description
3-8059-4AC	Four external dry-contact relays w/ power supply
3-8059-4	Four external dry-contact relays
3-8050.396	RC Filter Kit
6205-0002	DIN Rail, 1m
6205-0003	End Clips, DIN Rail

- The 8900 will support up to eight (8) relays, though only four actually fit directly inside its compact 1/4 DIN enclosure. 8059 External Relay Modules of four relays may be connected to the 8900 via digital (S³L) at the I/O Module (this does NOT consume a sensor input channel).
- External relays are completely independent of internal relays, so it is not necessary for Relays 1 & 2 or 3 & 4 to be installed in order to use the external relays. In the 8900 menus, external relays will always be identified as Relays A, B, C and D.
- 8059 versions with power supply are powered by universal AC line voltage and may be used to power the 8900 with 24 VDC. Also, digital (S³L) pass-thru terminals on the 8059 can help to reduce sensor wiring congestion at the 8900. See the 8059 instruction manual for details.
- External Relays mount on DIN rail inside a panel and can be tested remotely from the 8900, or locally with switches built-in for convenience. They also include LED relay status indicators, but the status of these and all relays is available at all times in a single screen in the 8900 View mode.
- Any and all relays are freely assignable to any channel. Hysteresis and time delay are adjustable for each relay.
- It is perfectly acceptable to mix and match relay types between internal and external modules. However, NOTE: The 8900 only allows external relays to be used in modes Off, Low, Hi, Window, USP and Advanced.
- 8059 External Relay Modules contain dry-contact relays only. These electromechanical switches are suitable for many general-purpose applications, AC or DC, including AC loads up to 250 V.
- Switching active loads (most commonly inductive) can cause contact arcing sufficient to damage relays. The RC Filter Kit or “snubber” is available as an accessory to reduce or eliminate these damaging effects.

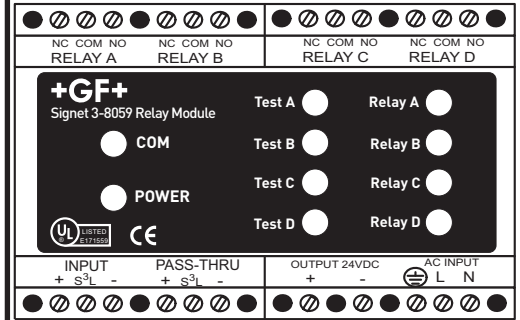

8059-4AC

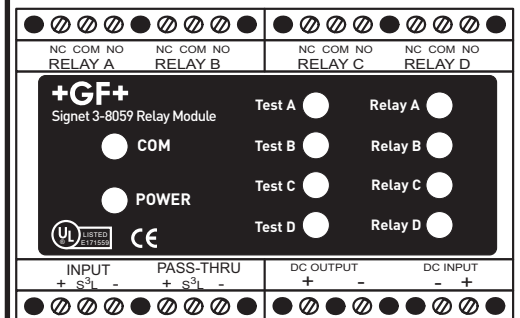

8059-4

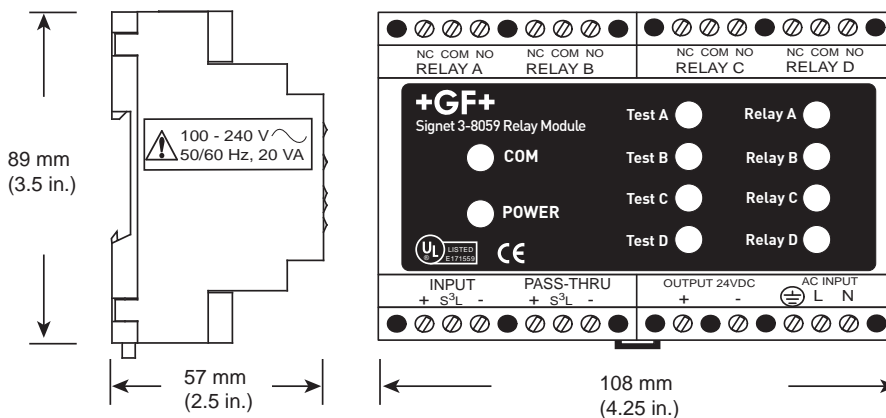

5. Mounting the Base Unit

The 8900 may be mounted in a panel, on a wall, or on virtually any surface including shelves, racks and pipes. All methods of mounting the 8900 make use of the Signet Quick-clip for holding the instrument securely in place. This unique clip eliminates the hassle of locating and drilling holes for mounting screws.

If the 8900 will be mounted in a panel, plug-in modules may be installed either before or after the base unit is mounted. If an accessory Wall Mount Bracket will be used, first install plug-in modules.

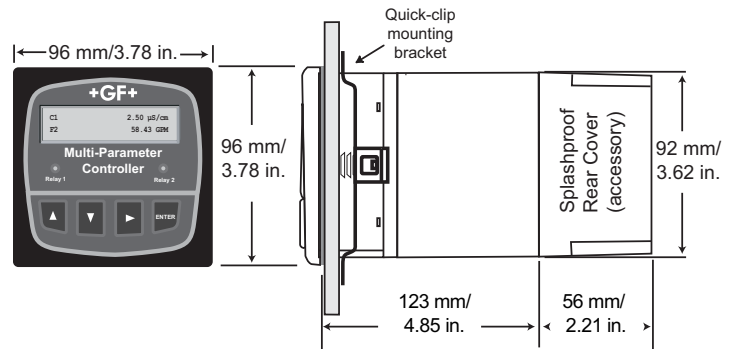

5.1 Panel Mounting

- The 8900 enclosure conforms to the 1/4-DIN standard, which requires a panel opening of 92 mm x 92 mm (3.6 in. x 3.6 in.).
- 1/4-DIN punches are available and recommended for creating clean, precise openings quickly and easily in most instrument panels.
- Alternatively, a jigsaw or other cutting tool may be used. An adhesive template is provided to help guide the cutting process.
- Recommended minimum clearance on all sides between instruments and panel edges is 25 mm (1 in.) as illustrated.
- Use an appropriate file as necessary to shape and size the opening, and to remove burrs.

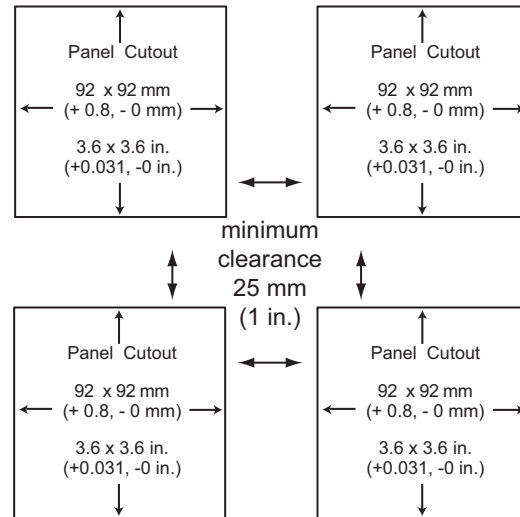

3-5000.399 Panel adapter, 5 in. x 5 in. to 1/4-DIN

3-8050.392 Panel adapter, 1/2-DIN to 1/4-DIN

- Two panel adapter accessories are available for installing the 8900 into panels with existing cutouts larger than the 1/4 DIN standard.

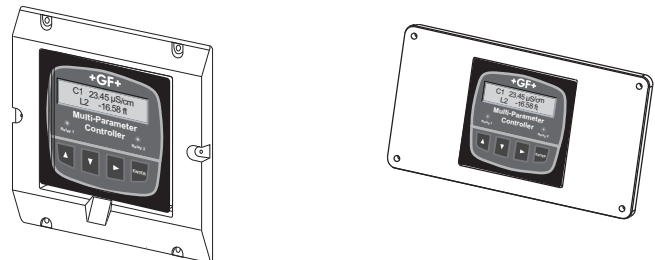

To install 8900 in a panel:

- Slide the 8900 into the opening from the front of the panel. Ensure the Front Face Panel Gasket is properly seated against the panel and around the instrument case.
 - Slide the Quick-clip mounting bracket over the back of the instrument as illustrated. The Quick-clips will snap into engagement with the molded latches on the side of the instrument. Press the bracket against the inside of the panel to secure the instrument firmly in place.
- To remove, press the Quick-clips outward while pulling the bracket away from the instrument panel. **DO NOT ALLOW THE INSTRUMENT TO FALL FORWARD OUT OF THE PANEL OPENING!** It may be necessary/helpful to temporarily secure the instrument from the front with tape, etc.

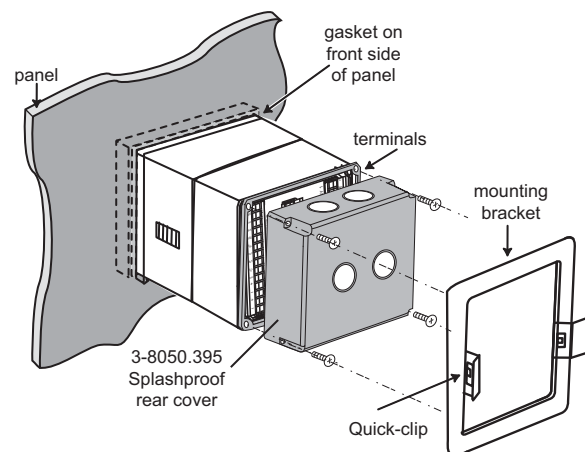

5.2 Mounting Accessories

Mfr. Part No.
3-8050.395

Description
Splashproof rear cover

- Use in conjunction with liquid tight connector kits to seal wiring ports.
- Protects rear of instrument and terminals from moisture intrusion and corrosion.
- Suitable for indoor and outdoor installations.
- 3-9000.392 Liquid tight connector kit, NPT (3 connectors)
- 3-9000.392-1 Liquid tight connector kit, NPT (1 connector)
- 3-9000.392-2 Liquid tight connector kit, PG13.5 (1 connector)

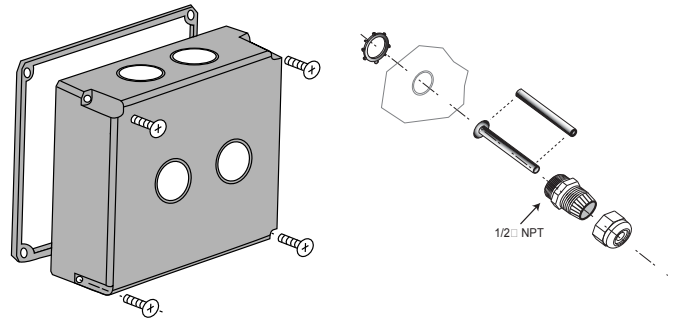

Mfr. Part No.
3-5000.399

Description
Panel adapter, 5 in. x 5 in. to ¼-DIN

- Converts 127 mm x 127 mm (5 in. x 5 in.) panel cutouts to ¼-DIN
- Primarily used when replacing retired 500-series Signet instruments with modern ¼-DIN instruments
- Injection molded black plastic (Acetal)
- Neoprene gasket and machine screw hardware included

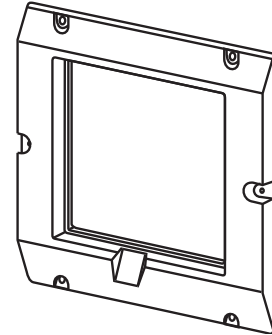

Mfr. Part No.
3-8050.392

Description
Panel adapter, ½-DIN to ¼-DIN

- Converts existing panel cutouts, up to 96 mm x 192 mm (3.8 in. x 7.6 in.), to ¼-DIN (92 mm x 92 mm)
- Powder coated aluminum, black, 3.2 mm (0.125 in.) thick
- Neoprene gasket and machine screw hardware included

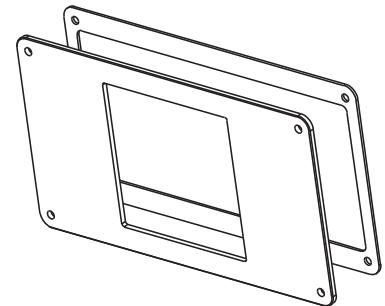

Mfr. Part No.
3-5000.598

Description
Shelf/pipe mount bracket, ¼-DIN instrument

- Use for surface mount installations under a shelf, or on a counter or rack.
- Powder coated aluminum, black, 3.2 mm (0.125 in.) thick
- Nylon straps or other suitable fasteners may be used to secure this bracket to a pipe.

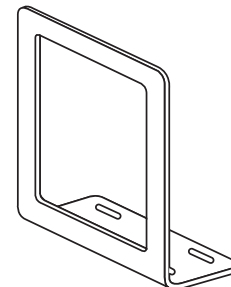

Mfr. Part No.
3-0000.596-1

Description
¼-DIN wall mount bracket, 6.5 in. depth

- Use to mount the 8900 (without a splashproof rear cover) to a solid wall or bulkhead.
- Powder coated aluminum, black, 3.2 mm (0.125 in.) thick

3-0000.596-2

¼-DIN wall mount bracket, 9.0 in. depth

- Use to mount the 8900 (with a Splashproof rear cover) to a solid wall or bulkhead.
- Powder coated aluminum, black, 3.2 mm (0.125 in.) thick

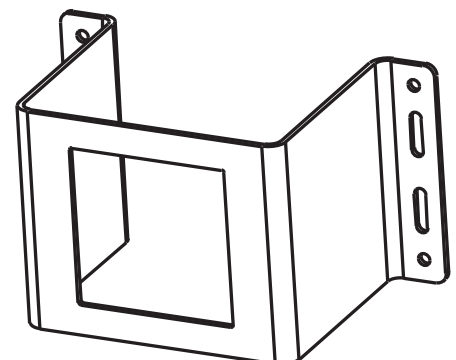

6. Wiring

All wiring connections to the 8900 are made via the removable terminals of the plug-in modules. This section contains instructions and diagrams for wiring each type of module. Several helpful tables, explanations and recommendations are also provided. In general:

- Do not allow any AC leads that may be connected to the Power Module, or to optional internal relays, to come in contact with low voltage wiring.
- Terminals accept 12 to 24 AWG wire.
- Strip 10 mm to 12 mm (0.4 in. to 0.5 in.) of insulation from wire tips and tin bare ends to eliminate fraying.
- Use ferrules when connecting more than one wire to a single terminal.
- Insert wire tip or ferrule completely into the terminal and secure with the screw.
- The I/O Module provides the terminals for sensor inputs, optional external relays, and optional Analog Outputs 1 & 2.
- These modules (3-8900.401-X) support frequency and digital (S³L) sensor input signal types. External relays are controlled via digital (S³L) and connect to the I/O Module just as if they were digital (S³L) sensors. External relays do NOT consume a sensor input channel.
- Refer to Section 6.4: Output Module for wiring optional Analog Outputs 1 & 2.

6.1 Signal Type: Frequency

The maximum allowable cable length for flow sensors with frequency output is dependent upon the output signal strength of the sensors themselves, and the degree to which the signals are susceptible to EMI or "noise". This is largely a function of whether the sensors are self-powered, or powered by an external source.

All of the sensors in the table below are compatible with the 8900. The three models limited to 60 m (200 ft) are self-powered sensors. The 8900 automatically provides power to the others via the I/O Module (normal sensor wiring).

These maximum recommended cable lengths apply to individual sensors and are completely independent of one another. Additionally, these cable lengths have no relevance to any digital (S³L) devices that may also be connected to the I/O Module.

Flow sensor models with Frequency Output										
Maximum Cable Length	515	525	2000	2100	2507	2536	2537	2540	2551	2552
60 m (200 ft)	X	X								
305 m (1000 ft)			X	X	X	X	X	X	X	X

Frequency Input Wiring

The 8900 accepts one or two frequency inputs. Each input will occupy one channel.

The frequency input connected to terminals 1-2-3 will be identified in the 8900 menu as "Freq. in 1."

The frequency input connected to terminals 4-5-7 will be identified in the 8900 menu as "Freq. in 2."

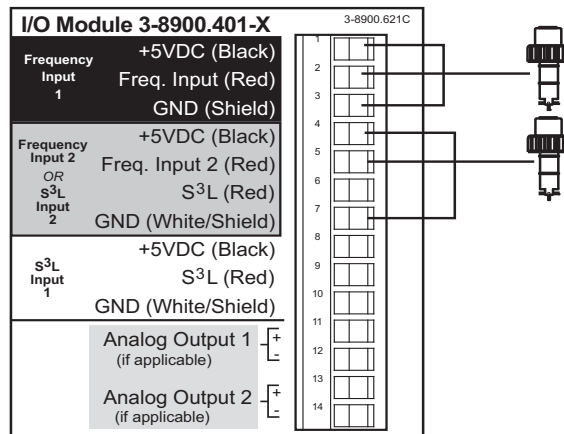

6.2 Digital (S³L) Input wiring

- The maximum cable length of the digital (S³L) bus varies depending on the types of sensors connected and the size of the conductors in the cable. For best results, determine the maximum cable length for the system before routing cables.
- Frequency input signals from flow sensors are not part of the digital bus, so they do not impact the cabling calculations. Follow the maximum cable specifications published in the flow sensor literature.
- The digital (S³L) bus can be connected to two sets of terminals on the 8900. Divide digital (S³L) sensors between the two points to stay within the limits defined here.
- There are several methods that can help route the digital cables and remain within the distance limitations. The following pages provide general wiring concepts for different systems.

* 2551/2552 Magmeter and the 8900

The 2551 or 2552 Magmeter may require up to 15 mA per unit under some conditions. Special attention must be paid to power requirements when more than three 2551 or 2552 Magmeters are connected to the 8900.

To ensure that Magmeters receive sufficient power, Signet recommends minimizing other power requirements in the 8900 by doing at least ONE of the following:

- Select solid state relay cards instead of dry contact relays.
- Select Passive analog output cards instead of Active.
- Select the DC power supply card instead of the AC card.

Any one of these measures will insure that the 8900 has sufficient power available to support up to six 2551 or 2552 Magmeters.

How to Wire Digital (S³L) Sensors

1. Tie all red wires together.
2. Tie all white wires together.
3. Tie all black wires together.
4. Tie cable shield to white GND wire at one end only for added protection from noise interference.

Notes:

- Some installations may require connecting the cable shield to Earth ground to overcome noise interference.
- Terminals 4-7 may be used as Freq Input 2 or as digital (S³L) Input 2, but not both.
- For best EMI filtering, divide digital sensors between S³L Input 1 and S³L Input 2 if Input 2 is not required for Frequency input.
- Daisy-chain or multi-drop wiring for digital (S³L) devices will reduce the number of separate digital signal lines that must be connected to the 8900 I/O Module.
- Ferrules are recommended when connecting multiple digital (S³L) devices to a single set of terminals.
- In a "Daisy-Chain" pattern, the wires from each sensor are spliced to the matching wire of the adjacent sensor.
- In a "Multi-Drop" pattern, the wires from each sensor are spliced to a common set of wires from the 8900.
- Wiring methods can be mixed in any convenient design when connecting digital (S³L) devices. See the wiring charts on the following pages for a variety of wiring options.
- The specific type of sensors on a branch of the digital (S³L) bus determine the current requirements, and the maximum cable length for the branch. See section 6.2.1 for details.

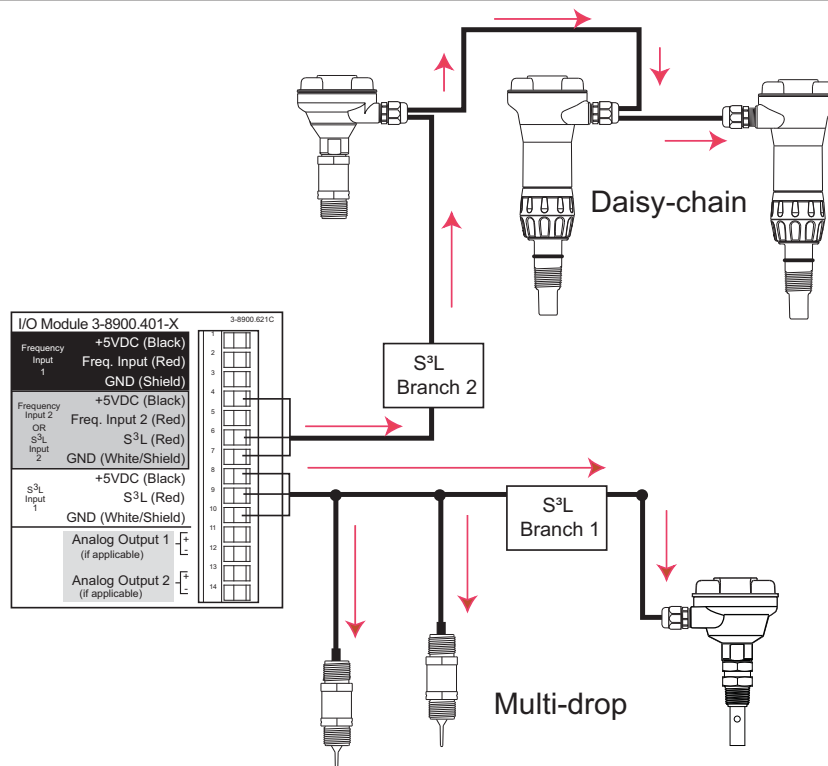

6.2.1 Digital Cable Length Calculations

Step 1: Calculate the Total current requirements for digital (S³L) Branches

This information will determine the total current consumption of all digital (S³L) sensors on a branch of the digital (S³L) bus, as a means of determining if the sensor load is within the current rating of the cable.

Fill in the chart to determine the current requirements for a specific set of sensors.

Maximum Current Consumption for Digital S³L Devices

	Current	Quantity	Total	
<u>2350 Temperature Sensor</u>	1 mA X	_____ =	_____	Example: none 2 Press 1 mA x 2 = 2 mA 2 Mags 15 mA x 2 = 30 mA 2 pH 3 mA x 2 = 6 mA none none none Total 38 mA
<u>2450 Pressure Sensor</u>	1 mA X	_____ =	_____	
<u>2551/2552 Magmeter*</u>	15 mA X	_____ =	_____	
<u>2750 pH/ORP Sensor Electronics</u>	3 mA X	_____ =	_____	
<u>2850 Cond. Sensor Electronics</u>	2 mA X	_____ =	_____	
8058 Current-S3L Converter	3 mA X	_____ =	_____	
<u>8059 External Relay Module**</u>	1 mA X	_____ =	_____	
<u>Total current requirement on digital (S³L) bus</u>			_____ mA	

** The digital (S³L) communication link between the 8900 and the 8059 is powered by the 8900 and consumes 1 mA maximum. However, the 8059 External Relay Module always requires a separate power source for its operation.

Step 2 Determine the Maximum length of each branch of the digital (S³L) Bus

This chart determines the maximum length of one branch of the digital (S³L) bus. This distance is important because it ensures that the digital signal can successfully travel the length of the cable and still be detected by the 8900.

- Find the column nearest to the total current in this branch, as determined in step 1.
- Find the cable gauge or wire dimensions that most accurately represent the cable being used.
- The number at the intersection of these factors represents the maximum cable for one branch of the digital (S³L) bus.
- The top section references AWG cables, the lower section is based on METRIC cables.
- Dividing the sensors between two branches will greatly increase the maximum cable length of each branch.

Example: 40 mA total on one branch can sustain 70 ft of cable. 20 mA on two branches can sustain 140 ft on each branch.

Maximum Cable (AWG)

AWG	Ω/ft	Power Supply Current (mA)										Feet
		1	2	4	10	15	20	40	60	90		
24	0.0277	1800	900	450	180	120	90	40	30	20		
22	0.0175	2850	1420	710	280	190	140	70	40	30		
20	0.0109	3000	2290	1140	450	300	220	110	70	50		
18	0.0069	3000	3000	1810	720	480	360	180	120	80		
16	0.0044	3000	3000	2840	1130	750	560	280	180	120		

Maximum Cable (Metric)

Area mm ²	Diameter mm	Ω/m	Power Supply Current (mA)										Meters
			1	2	4	10	15	20	40	60	90		
0.2	0.50463	0.0885	560	280	140	50	30	20	10	0	0		
0.25	0.56419	0.0708	700	350	170	70	40	30	10	10	0		
0.5	0.79789	0.0354	900	700	350	140	90	70	30	20	10		
0.75	0.97721	0.0236	900	900	520	210	140	100	50	30	20		
1	1.12839	0.0177	900	900	700	280	180	140	70	40	30		
1.5	1.38199	0.0118	900	900	900	420	280	210	100	70	40		

Step 3 Determine the Maximum total cable length of the digital (S³L) Bus

The quality of the cable used in the bus determines the maximum length of all branches combined.

The maximum cable length may not exceed these limits, regardless of current requirements.

Cable	Max. Total Distance	Comments
Capacitance (pF/ft)		
<50 pF/ft	900 ft	Even the most economical cables meet this specification.
<30 pF/ft	1500 ft	Cables from Signet fall into this category.
<15 pF/ft	3000 ft	Cables meeting this specification are very expensive network cables.
pF/m		
<150 pF/m	300 m	Even the most economical cables meet this specification.
<100 pF/m	450 m	Cables from Signet fall into this category.
<50 pF/m	900 m	Cables meeting this specification are very expensive network cables.

6.2.2 Digital Cable Routing Diagrams

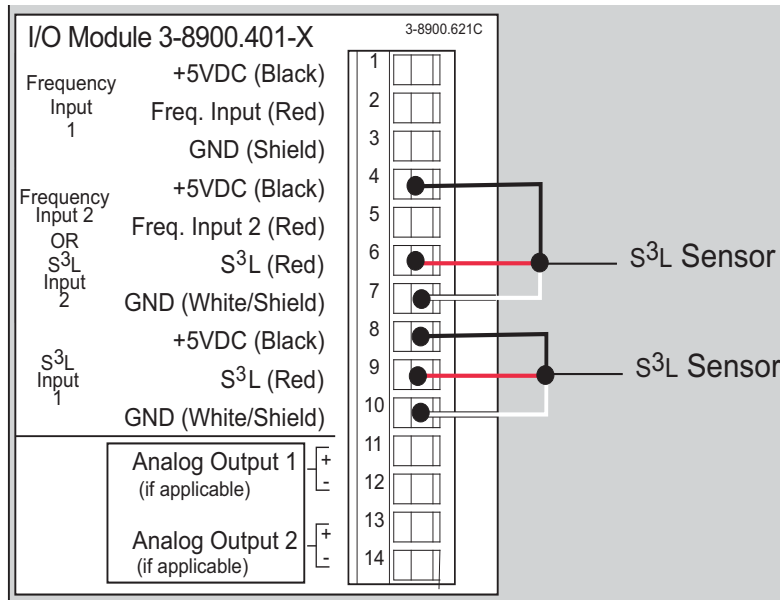

If two digital (S³L) sensors are wired separately, the cable length of each branch can be extended.

If terminals 4-6-7 are used for digital (S³L), the 8900 cannot accommodate two frequency inputs.

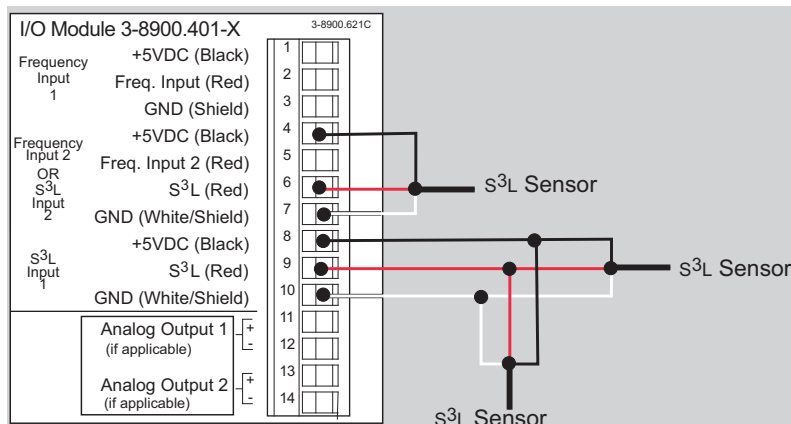
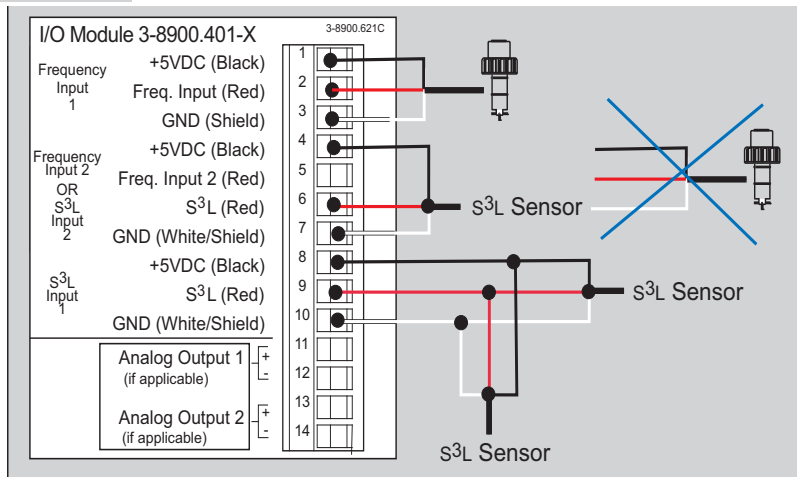

To add a digital sensor to the digital (S³L) bus, connect the RED, BLACK and WHITE wires into the existing bus at any point.

The new sensor is added to terminals 4-6-7 so the sensor load is divided between the two branches of the bus

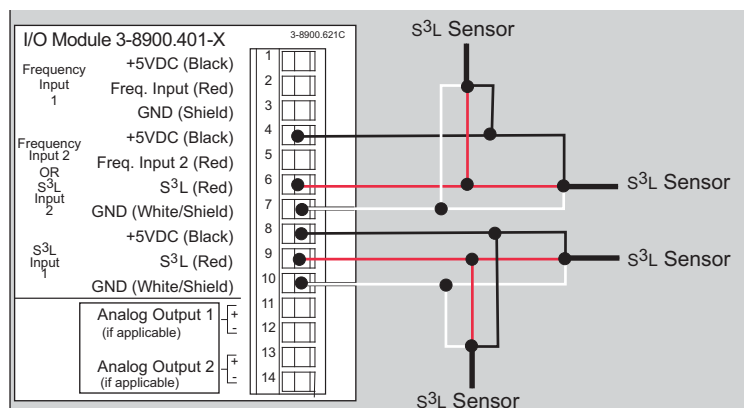

- This diagram shows five digital (S³L) sensors.
- A flow sensor with a frequency output can be added to terminals 1-2-3 to complete the system.

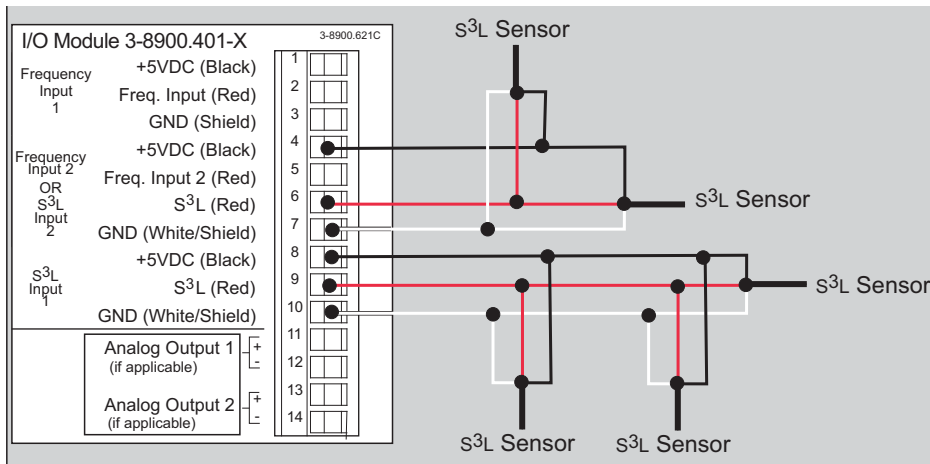

- If two frequency inputs are used, connect up to four digital sensors to terminals 8-9-10.
- One 8059 External Relay Module can also be added to the bus.

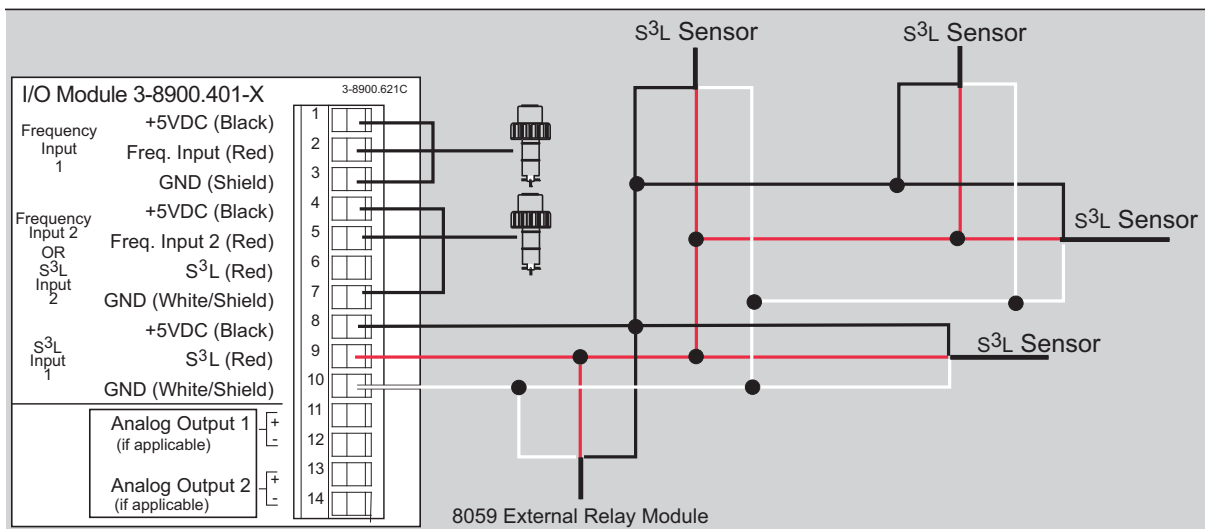

- Divide digital (S³L) sensors evenly between terminals whenever possible.
- With six digital (S³L) inputs, no frequency inputs can be added to this system.
- One 8059 External Relay Module can be added to the bus regardless of the number of digital (S³L) sensors present.

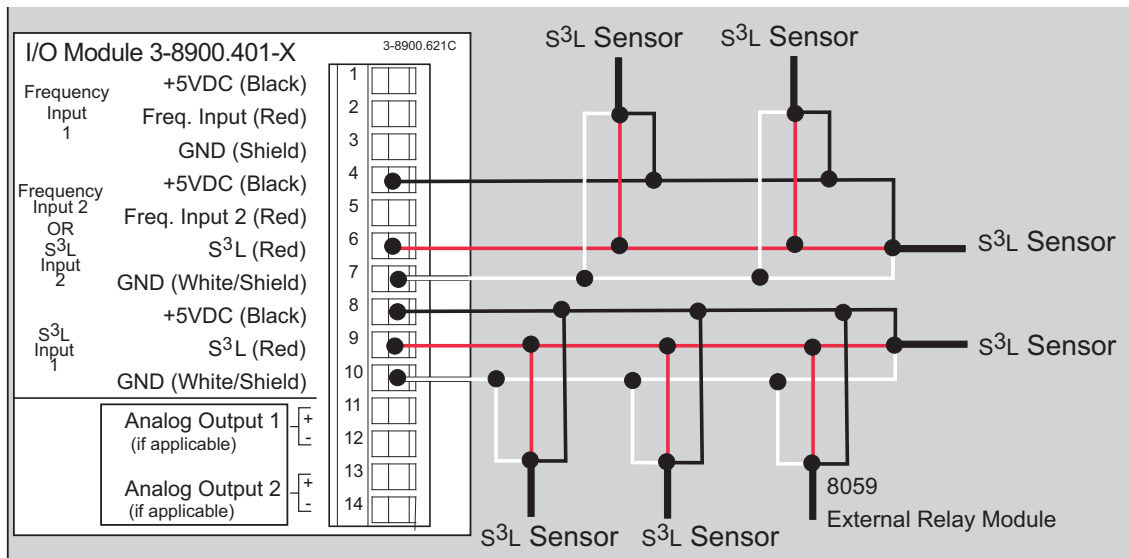

6.3 Power Module (3-8900.402-X)

- The 8900 can operate from a Universal AC power input (3-8900.402-1) or from a 24 VDC power input (3-8900.402-2)
- For safety, place the AC ONLY or DC ONLY decal on the rear panel of the 8900.
- Exceeding voltage ratings may damage the unit and pose a shock hazard.
- The DC power module has more power capability than the AC module, and is recommended for systems where the sensor load exceeds 40 mA.

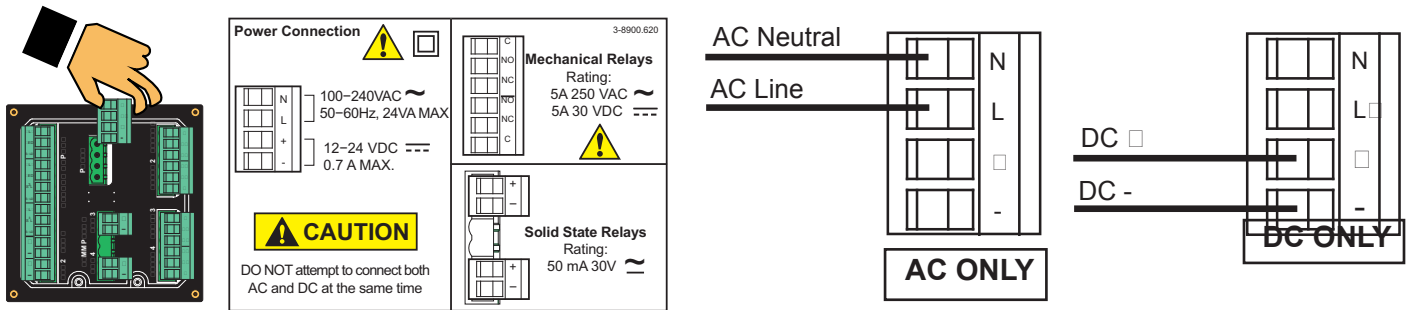

6.4 Output Module (3-8900.405-X)

The 8900 will support up to four analog outputs.

- Analog outputs 3 & 4 are obtained via these separate plug-in modules.
- Analog outputs 1 & 2 are located on selected I/O Modules and are also wired as shown here.

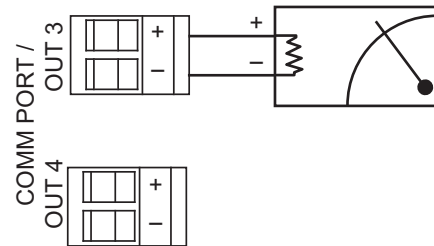
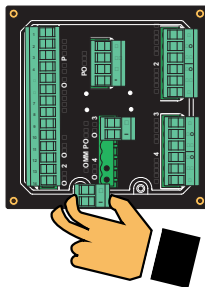

Active 4 to 20 mA loop wiring

- Active 4 to 20 mA Loop Output Module
The DC power required for the loop is supplied by the 8900. No additional power source is needed.
- Passive 4 to 20 mA Loop Output Module
The DC power required for the loop must be provided by an external source.

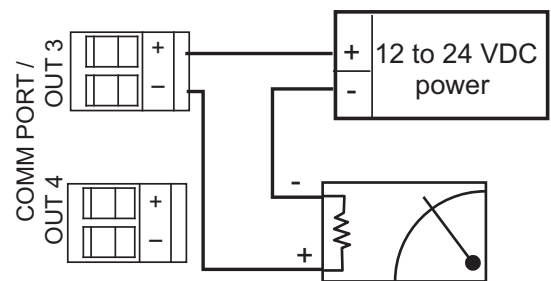

Passive 4 to 20 mA loop wiring

6.5 Relay Module (3-8900.403-X)

Solid State Relays (non-mechanical switches)

Normally open/closed operation:

Max. pulse rate:	Software selectable 600 pulses per minute (volumetric pulse & PWM modes) 400 pulses per minute (prop. pulse mode)
Max. voltage rating:	30 VDC or 42 VAC p-p
Current rating:	50 mA DC or 50 mA AC RMS
On-state impedance:	30 ohms or less
Off-state leakage:	400 nA or less, AC or DC
Isolation:	Up to 48 VDC, or 48 VAC p-p
Transient protection:	Embedded, up to 48 V over-voltage

Dry-contact Relays (mechanical contacts)

Type:	SPDT
Form:	C
Max. pulse rate:	600 pulses per minute (volumetric pulse & PWM modes) 400 pulses per minute (prop. pulse mode)
Max. voltage rating:	30 VDC or 250 VAC
Current rating:	5 A

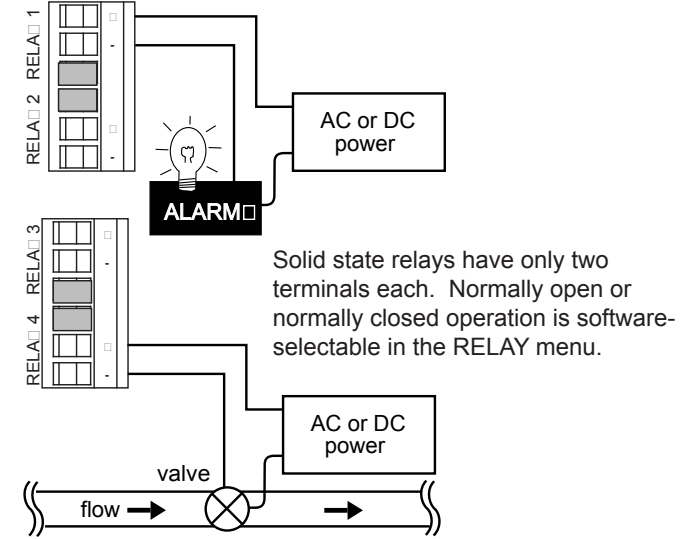
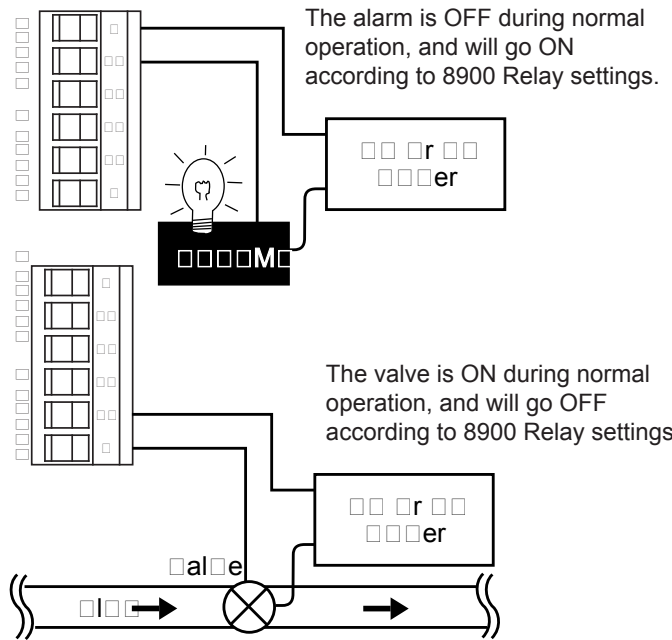
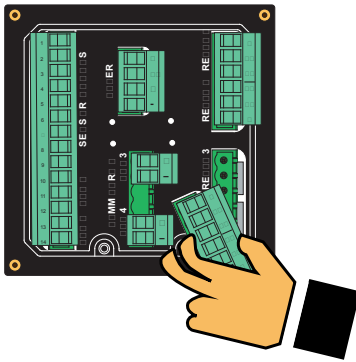

6.6 8059 External Relay Module

- 8059 external relay modules provide 4 additional dry-contact relays.
- External modules are controlled via the digital (S³L) serial bus.

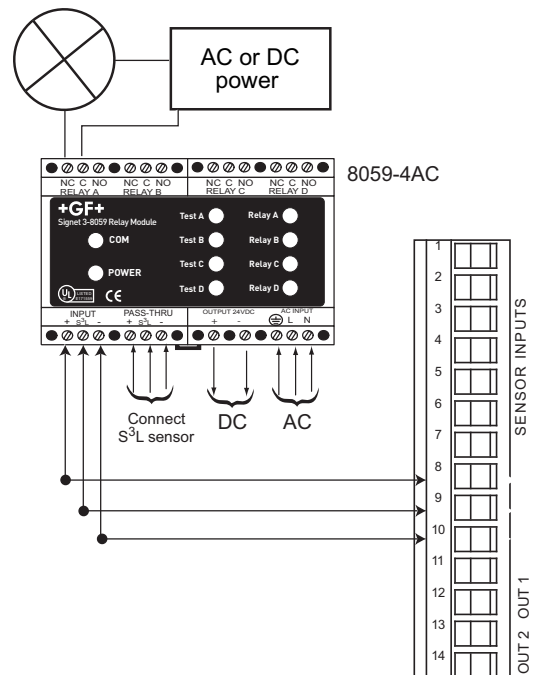
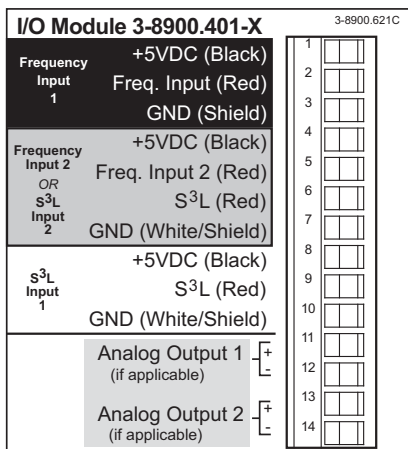

7. Operational Overview

The 8900 Multi-Parameter Controller belongs to the ProcessPro family of instruments. Each member of this family features a digital display and a four-button keypad for system set-up and general operation. This section contains a description of keypad functions, a general operation flowchart, and View mode details for the 8900.

Keypad Functions

The four buttons of the keypad are used to navigate display modes according to the descriptions in this table. Notice that the function of each button may change depending on the display mode.



Display Mode				ENTER	
View	Scroll through items in View	Select items marked with	to Menu Directory	No function	Pressed simultaneously
Menu Directory	Scroll through items in Menu Directory	Scroll DOWN through items in Menu Directory	Select menu	Return to View	
Menu	Scroll through items in Menu	Select menu item for editing	No function	Return to Menu Directory	
Edit	Scroll through flashing items, or edit flashing character	Scroll DOWN through flashing items, or advance flashing cursor	Save new setting	Escape to menu item without saving new setting	
Function					

7.1 General Operation Flowchart

The four display modes of the 8900 are layered as shown in the flowchart below. Keypad symbols illustrate basic navigation within and between these modes.

- **View:** View mode is normal operation for the 8900. After system setup is completed, all measurement values for each channel, plus the status of any analog outputs and relays will be available. See Section 8.4: Automatic Display Configurations and Section 8.5: Other Automatic Displays for details.
- **Menu Directory:** The Menu Directory provides access to seven separate menus for set-up and operation. There are two ways to access the Menu Directory from View.
 1. Scroll to the Menu Directory item and press the Right-arrow button.
 2. From any item in View, press and hold the ENTER button for 2 seconds.
- **Menu:** The current setting for each item in a Menu can be viewed and selected for editing from this mode.
- **Edit:** Access to this mode is password protected. Use the Standard password (UP-UP-UP-DOWN), or create a custom Enhanced password (see Section 14.1: Password Security). Entering the correct password one time allows access to all editable items in all menus, until a return to View mode.

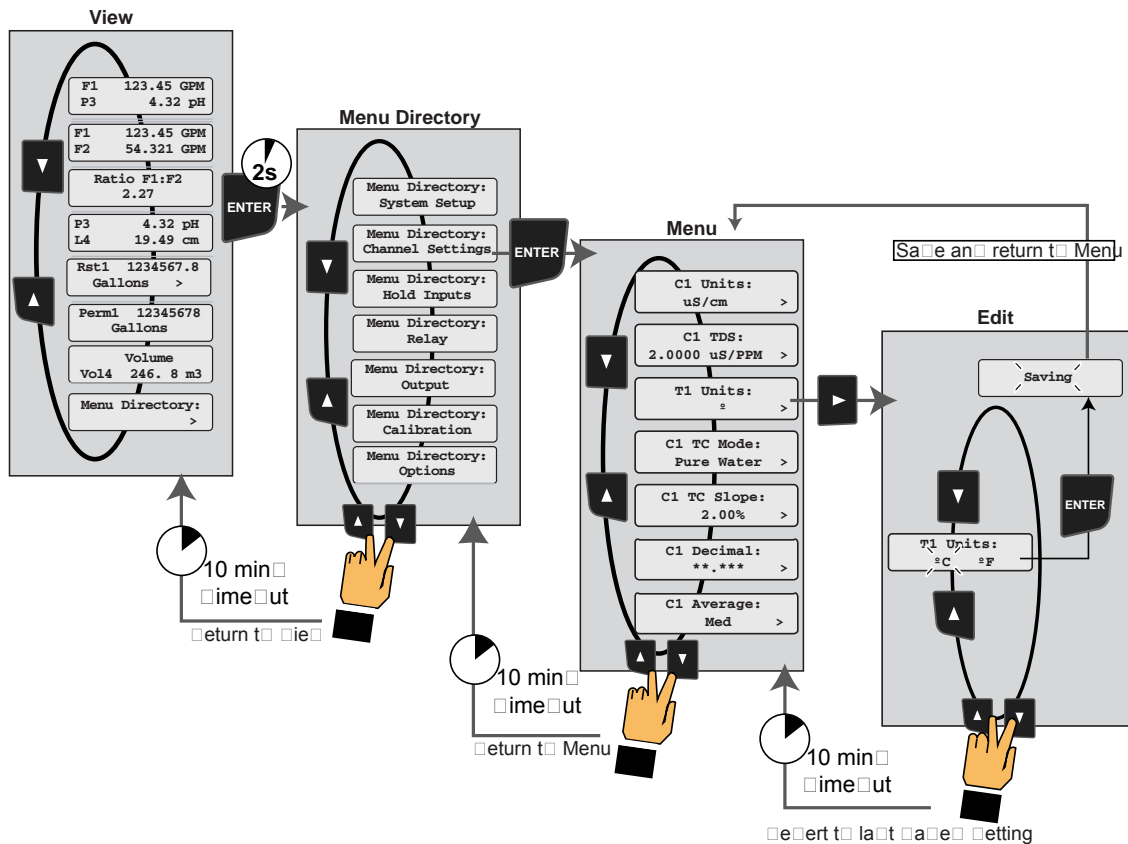

7.2 System Configuration

- Selecting this item will initiate an auto-scrolling inventory of the plug-in modules installed in the unit.

System Config:
>

- The order in which items appear is as follows:

Sensor Inputs:
of channels

Outputs 1 & 2:
type or "None"

Power:
VAC or VDC

Comm/Out 3 & 4:
type or "None"

Relays 1 & 2:
type or "None"

External Relays:
detected or not

Outputs 1 & 2:
type or "None"

- To advance more quickly to the next screen, press any button during the auto-scrolling sequence.
- There is a 10 minute timeout from this item back to the first measurement display screen.

7.3 Menu Directory

- Select this item to exit View and go to the Menu Directory.
- The Menu Directory may also be reached from any item in View by pressing and holding the ENTER button for two seconds.
- The Menu Directory provides access to the seven separate menus of the 8900: System Setup, Channel Settings, Hold Inputs, Relay, Output, Calibration, and Options.
- The content and utility of each of these menus is described in the following pages.
- There is a 10 minute timeout from this item back to the first measurement display screen.

Menu Directory:
>

Menu Directory:
System Setup

8. System Setup Menu

All of the basic system setup functions are automated in the 8900, with the exception of Channel Type assignments. These must be done by the user. After Channel types are assigned, the 8900 will automatically complete all of the remaining tasks in the System Setup menu. This includes assigning each sensor connected to the 8900 to a matching channel, and configuring one display for each channel. After installation and wiring is completed, follow the steps below.

NOTE: Automatic Sensor Recognition occurs each time the 8900 is powered on. See the following page for additional information.

8.1 System Setup: Channel Type

Example: Set Channel 1 to operate as a Flow Channel:

1. Start from View Mode (normal operation). In a new unit, the View display depends on the type of I/O module.
2. Hold the ENTER key for 2 seconds. When the display shows "Menu Directory-System Setup", release, then press ENTER again.
3. Press the RIGHT key, then enter the password. (Factory standard setting is UP-UP-UP-DOWN, Enhanced is 0-0-0-0)
4. The channel type will be flashing "None". Press the DOWN key three times to scroll to "Flow".
5. Press the ENTER key to select Flow. The display will show two warning messages, then ask "Are You Sure?" Press the RIGHT key to change the flashing response to "Yes", then press the ENTER key to finalize the change.
6. The display will show "Saving" for a few seconds, then return to the root menu. Press the DOWN key to scroll to the next channel type setting, then repeat steps 4 and 5.
7. If all settings in this menu are complete, press the UP and DOWN keys together again to return to the Menu Directory.
8. Press the UP and DOWN keys together once more to return to the View mode and normal operation. The display will now show the information from the sensor assigned to Channel 1.

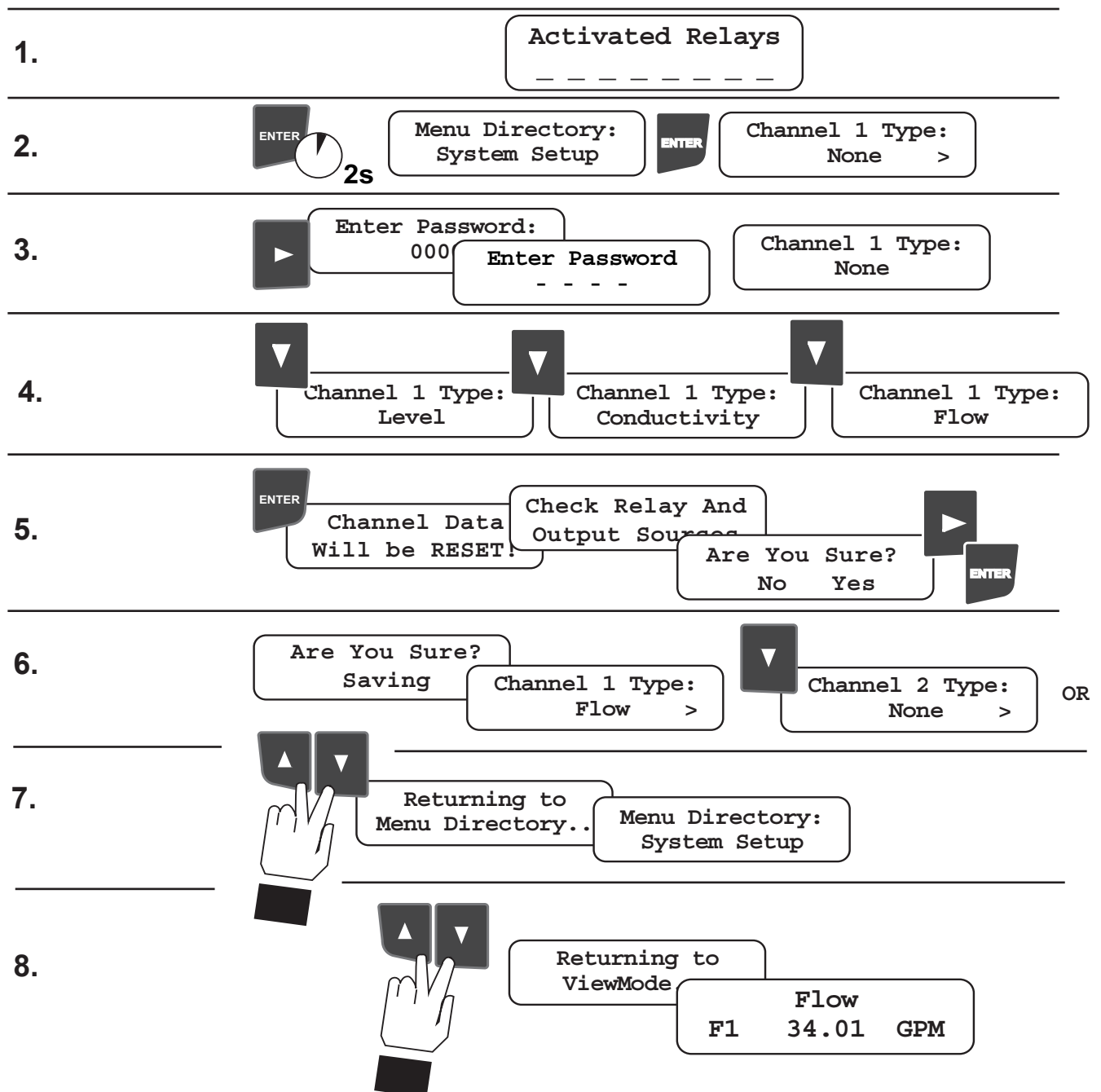

8.2 Automatic Sensor Recognition:

- Digital (S³L) sensors are detected at every power up, and placed on a list that identifies each by type and serial number. When new digital (S³L) sensors are detected, the 8900 displays **"Found New S³L Devices"**, then **"Loading...Please wait"**. When completed, the display shows how many sensors are connected, and whether a Relay Module is detected.

Manual override option:

The **"Load S³L Devices"** function in the System Setup menu can be used to manually initiate the search for new sensors and to verify that all sensors are detected on the digital (S³L) bus.

6 Sensor(s) and
1 Ext Relay(s)

8.3 Automatic Channel Assignment:

After a channel type is assigned (section 8.1), the 8900 compares the sensor identification list with each channel type and assigns a sensor to each channel, following a specific hierarchy:

- All Channels: Native sensors (sensors of the same measurement type as the channel type) will be assigned first. If multiple sensors of the same type are listed, the lowest serial number will be assigned first. Frequency inputs are considered the native type for flow channels.
- All Channels: 4 to 20 mA sensors (from 8058 Signal Converter) will be assigned only if no native sensors are listed. If no compatible sensors are listed for a channel, or if all compatible sensors are already assigned, then no automatic channel assignment will be made.
- Flow Channels: Digital (S³L) type flow sensor will be assigned only if no frequency input is detected. Level Channels: If no level sensors are listed, a pressure sensor will be assigned to the level channel.

Manual override option: Use the **"Channel ID"** function to reassign sensors.

- The Channel ID menu will only list sensors that match the channel type being assigned.
- Removing a sensor from the wiring bus does NOT erase a channel assignment. The display will show "CHK SENSOR" for that channel until a sensor is manually reassigned.

8.4 Automatic Display Configurations

- A new display will be automatically configured for each channel (only where one of the six configurable displays has both lines set to "None".)
- Conductivity, Level and pH channels are allotted two-line displays to view both primary and secondary measurements. All other channel types are assigned a single-line display.
- Standard displays for each channel type are illustrated below.

Manual override option: Configurable VIEW displays can be modified with the **"Screen--Line--"** functions in System Setup menu.

pH Channel

The default pH display shows the primary pH measurement on line 1 and the secondary temperature measurement on line 2.

pH1 8.6 pH
T1 29.7 °C

Flow Channel

The default Flow display shows the full name of the measurement type on line 1 and the measurement value on line 2.

Flow
F2 123.45 GPM

Conductivity Channel

The default Conductivity display shows the primary Conductivity measurement on line 1 and the secondary temperature measurement on line 2.

C3 17.54 µS/cm
T3 24.3 °C

Pressure Channel

The default Pressure display shows the full name of the measurement type on line 1 and the measurement value on line 2.

Pressure
P4 35.9 psi

Temperature Channel

The default Temperature display shows the full name of the measurement type on line 1 and the measurement value on line 2.

Temperature
T5 29.7 °C

Level Channel

The default Level display shows the primary Level measurement on line 1 and the secondary Volume measurement on line 2.

L4 12.58 ft
V4 987.65 ft3

ORP Channel

The default ORP display shows the full name of the measurement type on line 1 and the measurement value on line 2.

ORP
ORP6 128 mV

Other (4-20) Channel

The default Other (4-20) display shows "Label" on line 1 and the measurement value on line 2. NOTE: The channel label (Label), abbreviation (Ch) and unit of measure (Unit) settings must be customized for this type of channel. See section 9.8 "Channel Type Other (4-20)"

Label
Ch1 12.34 Unit

8.5 Other Automatic Displays

The 8900 will configure the following displays when appropriate:

- For each channel assigned to flow, two display screens will be added to View; one for a permanent totalizer (Perm~), and another for a resettable totalizer (Rst~):
- For each channel assigned to pH or ORP, a display screen showing the raw mV input from the sensor will be added.

Perm1 1234567.8
Gallons

Rst2 1234567.8
Gallons ▶

pH4 Input:
-6.027 mV

ORP3 Input:
763 mV

Analog Output Values

- The 8900 supports up to four analog outputs. If installed, output values will be displayed automatically, in pairs, in a format that cannot be modified.
- Outputs will remain in error condition (as shown in this example) until properly assigned in the Output menu, or until a true error affecting output source is remedied.
- There is a 10 minute timeout from this item back to the first measurement display screen. (The Autoscroll feature overrides the 10-minute timer.)

Output1 22.10 mA
Output2 22.10 mA

Relay Status Indicators

- The 8900 supports up to eight (8) relays; four internal, and four external. The four internal relays are numbered 1 through 4, and the four external relays are labeled A through D. In the Activated Relays screen, underscores (" _ ") are used to indicate relaxed or inactive relays.
- If a relay is activated, then its number or letter will replace the corresponding underscore. In the example below, relays 1 & 2 and A & B are activated:
- Relays that are not installed or connected will always be represented by the underscore.
- Relays will remain or become inactive (error condition) until properly assigned in the Relay menu, or until a true error affecting relay source is remedied.
- There is a 10 minute timeout from this item back to the first measurement display screen. (The Autoscroll feature overrides the 10-minute timer.)

Activated Relays
_ _ _ _ _

Activated Relays
1 2 _ _ A B _ _

Memo

- The second line of this screen is alphanumerically editable, up to 15 characters, via the Memo item in the Options menu.
- Use this field to record important dates such as system commissioning or scheduled maintenance, or the telephone number of your local Signet sales representative.
- There is a 10 minute timeout from this item back to the first measurement display screen. (The Autoscroll feature overrides the 10-minute timer.)

Memo:
gfsignet.com

8.6 Displays for Derived Functions

- Whenever two or more measurements of the same type are present in the 8900 setup, the following derived functions become available for like pairs: Sum, Difference, Ratio, % Recovery (flow), % Reject and % Passage (conductivity) Recovery A, Recovery B, Recovery C, Power 2, Power 4.
- These assignments are made in Function Type of the Options menu.
- The 8900 allows up to four derived functions to be used for display and control at any one time. An example of the display for derived functions is shown here. This format cannot be modified.

Reject C3→C4
99.1%

Ratio L3→L4
97.000

Diff T3→T4
10.58 °C

Power 2
40.943 kW

9. Channel Settings

The Channel Settings menu changes according to the channel type. This section shows the settings available for each type of sensor.

9.1 Channel Settings: If Channel Type = Flow:

F1 Units: GPM >	Set the units of measure for this flow channel. The last character sets the timebase: Select S (seconds) M (minutes) H (hours) D (days)
4mA Set Point 1: 5.0000 GPM >	If this channel is FLOW and the sensor is 4 to 20 mA, set the minimum and maximum setpoints.
20mA Set Point 1: 55.000 GPM >	
F1 K-Factor: 60.000 >	Set K-Factor (pulses per unit volume) from Flow Sensor manual: Minimum: 0.0001 Maximum: 99999. (Cannot be zero)
F1 Decimal: **.*** >	Select decimal resolution for Flow Rate display: XXXXX. XXXX.X XXX.XX XX.XXX X.XXXX
Tot1 Unit: Gallons >	This setting identifies the Totalizer units. It has no effect on any calculation. Up to eight (8) alphanumeric characters, upper & lower case, serve as a label only.
Tot1 Factor: 60.000 >	Tot~ Factor: Sets the volume of each count of the Totalizer as a multiple of the volume unit of the K-Factor: If K-Factor = pulses per gallon, and Tot~ Factor is set to 1.000, then Totalizer counts once per gallon; if Tot~ Factor is set to 10.00, then Totalizer counts once for every 10 gallons, etc. Minimum: 0.0001 Maximum: 99999. (Cannot be zero)
Tot1 Decimal: *****.** >	Select decimal resolution for Totalizer displays: XXXXXXXX. XXXXXXXX.X XXXXXX.XX
Tot1 Reset: Lock Off >	Lock On: EDIT code required to reset the Resettable totalizer to zero. Lock Off: No EDIT code required to reset the Resettable totalizer to zero.
F1 Average: Med >	Dampens display, output and relay response rates for this channel. Off: Near instantaneous updates Low: 4 s Med: 8 s Hi: 32 s

9.2 Channel Settings: If Channel Type = pH

T1 Units:
C >

Select the unit of measure for the temperature sensor inside the pH electrode: °C or °F

T1 Decimal:
****.* >

Select decimal resolution for pH TEMPERATURE display:
XXXXX. XXXX.X XXX.XX

4mA Set Point 1:
0.0000 pH >

If this channel type is pH and the sensor is 4 to 20 mA, set the minimum and maximum setpoints.

20mA Set Point 1:
14.000 pH >

pH1 Average:
Med >

Dampens display, output and relay response rates for this channel.
Off: Near instantaneous updates; **Low:** 4 second averaging;
Med: 8 second averaging; **Hi:** 32 second averaging

9.3 Channel Settings: If Channel Type = ORP

4mA Set Point 1:
-1000 mV >

If this channel type is ORP and the sensor is 4 to 20 mA, set the minimum and maximum setpoints.

20mA Set Point 1:
1000 mV >

ORP1 Average:
Med >

Dampens display, output and relay response rates for this channel.
Off: Near instantaneous updates
Low: 4 s **Med:** 8 s **Hi:** 32 s

9.4 Channel Settings: If Channel Type = Conductivity

C1 Units:
µS/cm >

Select the unit of measure for this conductivity channel:
µS/cm **mS/cm** **kΩ • cm** **MΩ • cm** **PPM or PPB (of TDS)**

4mA Set Point 1:
4.0000 µS >

If this Channel is CONDUCTIVITY and the sensor is 4 to 20 mA, set the minimum and maximum setpoints.

20mA Set Point 1
20.000 µS >

C1 TDS:
2.0000 µS/PPM >

If units for this channel are PPM or PPB: set the ratio of µS per PPM.
Minimum 0.01 µS per PPM **maximum 99999.9 µS per PPM**

T1 Units:
C >

Select the unit of measure for the temperature sensor inside the conductivity electrode:
°C **°F**

C1 TC Mode:
Pure Water >

Select method of temperature compensation:
None required for USP
Linear best for water with conductivity of more than 0.2 µS/cm (5.0 MΩ resistivity)
Pure Water best for water with conductivity of less than 0.2 µS/cm (5.0 MΩ resistivity)

C1 TC Slope:
2.00 % >

Nominal setting is 2% change in conductivity for each 1°C shift from 25°C.
Maximum setting is 9.99% per °C

C1 Decimal:
****.***** >

Select decimal location for this conductivity display:
XXXXX. **XXXX.X** **XXX.XX** **XX.XXX** **X.XXXX**

T1 Decimal:
******.*** >

Select decimal location for the temperature display associated with this conductivity sensor.
XXXXX. **XXXX.X** **XXX.XX**

C1 Average:
Med >

Dampens display, output and relay response rates for this channel.
Off: Near instantaneous updates
Low: 4 second averaging; **Med:** 8 second averaging; **Hi:** 32 second averaging.

9.5 Channel Settings: If Channel Type = Pressure

P1 Units: psi >	Select the unit of measure for this pressure channel : psi bar kPa
---------------------------	---

4mA Set Point 1: 00.000 psi >	If this Channel is PRESSURE and the sensor is 4 to 20 mA, set the minimum and maximum setpoints.
---	--

20mA Set Point 1 100.00 psi >

P1 Decimal: *.*** >	Select decimal location for this pressure display: XXXXX. XXXX.X XXX.XX XX.XXX
-------------------------------	--

P1 Average: Med >	Dampens display, output and relay response rates for this channel. Off: Near instantaneous updates Low: 4 second averaging; Med: 8 second averaging; Hi: 32 second averaging.
-----------------------------	---

9.6 Channel Settings: If Channel Type = Temperature

T1 Units: C >	Select the unit of measure for this temperature channel: °C or °F
-------------------------	--

4mA Set Point 1: 00.00 °C >	If this Channel is TEMPERATURE and the sensor is 4 to 20 mA, set the minimum and maximum setpoints.
---------------------------------------	---

20mA Set Point 1 100.00 °C >
--

T1 Average: Med >	Dampens display, output and relay response rates for this channel. Off: Near instantaneous updates Low: 4 s Med: 8 s Hi: 32 s
-----------------------------	---

9.7 Channel Settings: If Channel Type = Level

L1 Units: ft >	Select the unit of measure for this Level channel: cm m in ft
Show L1 in %: No >	Yes: Level measurement will be displayed as a percentage of full scale. No: Level measurement will be displayed in unit of measure selected in previous setting.
4mA Set Point 1: 00.000 ft >	If this Channel is LEVEL and the sensor is 4 to 20 mA, set the minimum and maximum setpoints.
20mA Set Point 1: 10.00 ft >	
L1 100%= 0.00 ft >	If level measurement will be displayed as a percentage, set the full scale value (100%) in units of measure.
L1 Decimal: **.*** >	Select the decimal location for this Level display. XXXXX. XXXX.X XXX.XX XX.XXX X.XXXX
Sensor 1 Offset: +XXX.XX ft >	Enter the distance (in units of measure) from the sensor to the zero reference point. See Appendix B: Level System Configuration for additional information.
Note: The following channel settings for Volume may be ignored if not applicable to the application.	
V1 Units: ft ³ >	Select the unit of measure for Volume displays from this level sensor: cm³ m³ in³ ft³ gal lit lb kg
Show V1 in %: No >	Yes: Volumetric measurements will be displayed as a percentage of full scale. No: Volumetric measurements will be displayed as units selected in previous setting.
V1 100% =: 0.0000 gal >	If Volume measurement will be displayed a percentage, set the full scale value (100%) in units of measure.
Spec Gravity L1: 1.0000 >	If a pressure sensor is used for Level measurement, enter the specific gravity of the fluid.
V1 Shape: Vert Cylinder >	Select the shape of the vessel where the level sensor is located. Vert Cylinder Horiz Cylinder Rectangular Custom

9.7 Channel Settings: If Channel Type = Level (continued)

V1 Diameter:
10.000 ft >

If Vert Cylinder or Horiz Cylinder is selected, enter the diameter of the cylinder.
0.0000 to 99999.

V1 Length:
5.0000 ft >

If Horiz Cylinder or Rectangular shape is selected, enter the length of the vessel.
0.0000 to 99999.

V1 Width:
2.0000 ft >

If Rectangular shape is selected, enter the width of the vessel.
0.0000 to 99999.

V1 Cal Points:
10 >

If Custom shape is selected, enter the number of measurement points to be used to characterize the vessel shape.
Minimum 2 points, maximum 20 points. A larger number of points improves accuracy.

L1 Measurement:
Manual >

Manual: Enter Level and Volume for each custom point. These points are typically determined by calculation.

Pt01: -1234.5 ft
V1: +5432.1 gal>

Automatic: Enter Volume only for each custom point. Use this method if the volume associated with each level can be easily measured.

V1 Decimal:
.* >

Select the decimal location for the Volume display. Must be consistent with the range:
XXXXX. XXXX.X XXX.XX XX.XXX X.XXXX

L1 Average:
Med >

Dampens display, output and relay response rates for this channel.
Off: Near instantaneous updates
Low: 4 s Med: 8 s Hi: 32 s

9.8 Channel Settings: If Channel Type = OTHER (4–20)

- The 8058 Signal Converter allows any 4 to 20 mA signal to serve as an input signal to the 8900.
- For example, a Dissolved Oxygen sensor with a 4 to 20 mA output might be connected to the 8900.
- The following menu items are available ONLY when the Channel Type is "OTHER (4-20)."

4-20mA Type 1: Label1***** >	The information here will appear as the full name of the channel. NOTE: If the last character in the label is (*), the label will be centered on the display. If the name is less than 11 characters, an asterisk MUST be placed at the end of the name Example: Turbidity*
4-20mA Abbrev. 1 Ch >	Select a two-character abbreviation for the channel. Example: DO
4-20mA Unit 1: Unit >	Select the unit of measure for this channel. Select any four characters. This selection does not affect the measurement. It serves as a label only.
4mA Set Point 1 0.00 °C >	Set the value to be represented by 4 mA input.
20mA Set Point 1 100.00 °C >	Set the value to be represented by 20 mA input.
4-20mA Decimal 1 *.**** >	Select the decimal location for this Level display: XXXXX. XXXX.X XXX.XX XX.XXX X.XXXX
4-20mA Average 1 Med >	Dampens display, output and relay response rates for this channel. Off: Near instantaneous updates Low: 4 s Med: 8 s Hi: 32 s

10. Hold Inputs

Hold time: min 5 10 30 60 ∞	Set the duration (in minutes) the channel should be held: 5 10 30 60 ∞ (infinite time, until manually released)
Hold Input: >	Holds status of input, output and relay functions (flow totalizers will continue counting, however). Useful during calibration to avoid false alarms and unwanted engagement of control equipment.
Un-Hold Input: >	Manually release the channel on hold. (Appears only when a channel is held)

11. Relay Mode Descriptions

The 8900 offers a wide selection of relay operating modes that enable the user to create complex control scenarios. Internal relays (those installed on the two Relay modules) can be configured for all of the available modes. External relays that are located in the 8059 External Relay module are limited to the basic relay modes as shown in the chart.

		Internal Relays									
		External Relays									
		Mode:	Off	Low	High	Window	USP	Advanced	Prop. Pulse	PWM	Vol. Pulse
Source:											
Measurements	Flow	X	X	X	X			X	X	X	
	pH	X	X	X	X			X	X		
	ORP (Redox)	X	X	X	X			X	X		
	Conductivity	X	X	X	X	X		X	X		
	Pressure	X	X	X	X						
	Temperature	X	X	X	X			X	X		
	Level	X	X	X	X			X	X		
Derived Functions	Sum	X	X	X	X			X	X		
	Difference	X	X	X	X			X	X		
	Ratio	X	X	X	X			X	X		
	% Reject	X	X	X	X			X	X		
	% Passage	X	X	X	X			X	X		
	% Recovery A	X	X	X	X			X	X		
	% Recovery B	X	X	X	X						
	% Recovery C	X	X	X	X						
	Power 2	X	X	X	X						
	Power 4	X	X	X	X						
Multiple	X	X	X	X		X					

Maximum Proportional Pulse rate: 400 pulses per minute

Low

- Relay is activated when the process variable is less than the setpoint.
- The relay is deactivated when the process variable becomes greater than the sum of the setpoint and the hysteresis.

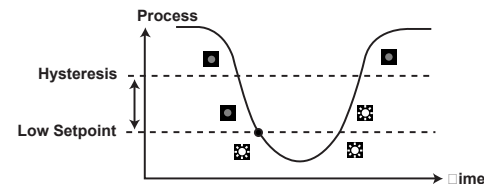

High

- Relay is activated when process variable is greater than the setpoint.
- The relay is deactivated when the process variable becomes less than the sum of the setpoint and the hysteresis.

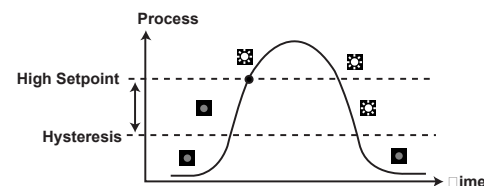

Window

- In Window mode, a single relay is activated when the process variable moves above or below a fixed window of values.
- The relay is deactivated when the process variable moves inside the window by more than the hysteresis value.

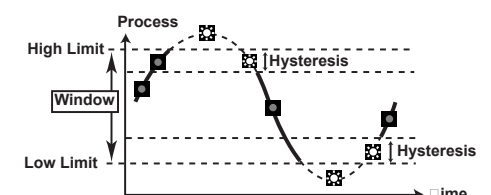

Proportional Pulsing

- Proportional Pulse mode varies the frequency of pulses in direct proportion to minimum and maximum setpoints.
- The 8900 does not allow use of this mode for Pressure applications.

Example:

- The output will be 0 pulses/min. at process values less than 5.0.
- The output will be 50 pulses/min. when the process value is 7.5.
- The output will be 100 pulses/min. at process values above 10.

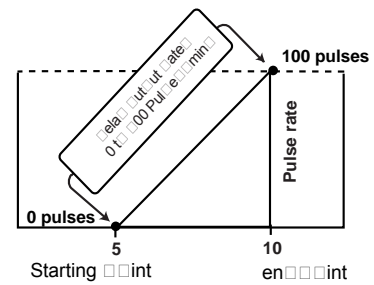

Pulse Width Modulation

- PWM automatically varies the ratio of ON time to OFF time proportional to minimum and maximum range settings.
- The relay period is the sum of the time a relay is ON and the time it is OFF.
- Relay pulse width is the time the relay is ON.
- The 8900 must be programmed with the relay period, and with the low and high setpoints.
- The 8900 does not allow use of this mode for Pressure applications.

Example:

- The pulse width will be 0% of the relay period (relay always OFF) when the process value is less than the minimum range.
- The pulse width will be 100% of the relay period (relay always ON) when the process value is greater than the maximum range.
- The pulse width will be 60% of the relay period when the process value is at 60% of the span between the minimum and maximum range.

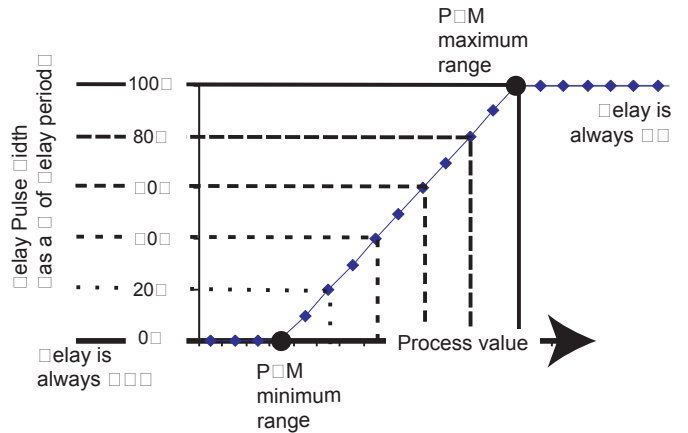

Volumetric Pulse

- A pulse is generated each time a specified volume of fluid is registered. For flow inputs only.

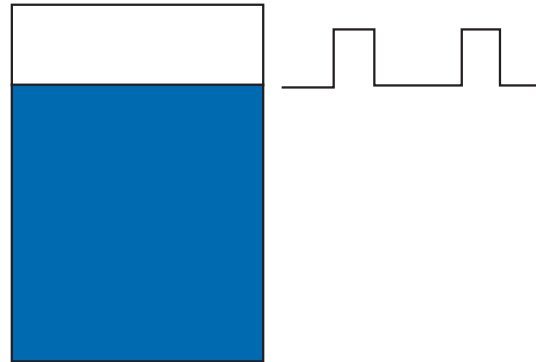

Totalizer Volume

- Relay activates and latches when a specified volume of fluid is registered. For flow inputs only.
- Total Volume mode counts the TOTALIZER Units until the setpoint volume is reached, then activates the relay until the resettable totalizer is reset.
- If the Resettable Totalizer reading is greater than the setpoint, the relay will be activated immediately. The relay will be relaxed when the totalizer is reset to zero.
- This mode is useful to trigger a reminder when a process is due, as for a backwash cycle or filter change.

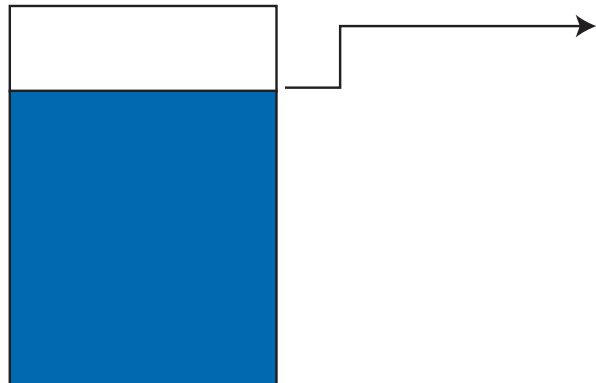

Advanced

- Relay is activated when a set of three conditions (a, b and c) are met. See detailed explanation in Section 11.2.

Relay 1 Operator:
 $(a \& (b \mid c)) >$

11.1 Relay Setup Menu

Relay 1 Source: Flow F1 >	Select measurement type or derived function to be assigned to this relay: Level, Volume, Temperature, Pressure, Flow, pH, ORP, Difference, Ratio, Conductivity, None, Sum, Reject, Passage, Recovery A, Recovery B, Recovery C, Power 2, Power 4, Multiple.
Relay 1 Mode: Low >	Select the mode of operation for this relay: Off, Low, High, Window, Prop Pulse, PWM, Volumetric Pulse, USP, Advanced.
Relay 1 SetPnt: 10.0 GPM >	If relay mode is Low or High: Enter the relay setpoint.
Relay 1 Rng: min +25.000 GPM >	If relay mode is Prop Pulse, PWM or Window: Enter the low-end setpoint.
Relay 1 Rng: max +45.000 GPM >	If relay mode is Prop Pulse, PWM or Window: Enter the high-end setpoint.
Relay 1 Period: 5.0 secs >	If relay mode is PWM, set the pulse period. Minimum 0.1 s, maximum 1000 s (16.7 minutes)
Relay 1 Hys: 5.0 GPM >	If relay mode is High, Low, Window or USP: Enter hysteresis.
Relay 1 Delay: 1.0 sec >	If relay mode is High, Low, Window or USP: Enter the trigger time delay. The relay will activate only if the process value exceeds the setpoint for this period of time. Minimum 0.1 s, maximum 6400 s (106.67 minutes)
Relay 1 maxRate: 120 pls/min >	If relay mode is Pulse: Set the maximum pulse rate. (1 to 400 pulses per minute.)
Relay 1 Volume: 100.00 Gallons >	If relay mode is Vol Pulse (Flow): Set the volume represented by one pulse.
Relay 1 P.Width: 0.1 secs >	If Relay mode is pulse: Set the duration of the relay pulse. Minimum 0.1 s, maximum 999.9 s (16.66 minutes)
Relay 1 Logic: N.O. >	For solid state relays only: N.C. = Normally Closed N.O. = Normally Open
Test Relay 1: >	Manually toggle relay to test operation.

11.2 Multiple Relay Sources and Advanced Relay Mode

When a Relay Source is set to "MULTIPLE" and the Relay Mode is set to "Advanced", the relay can be activated by up to three different conditions. ADVANCED mode presents four Boolean logic formulae called "Relay Operators." Each Operator can be programmed with up to three different conditions. The relay will only be activated when the complete formula is satisfied.

- A TRUE condition means that the parameter is beyond the setpoint.
- A FALSE condition means that the parameter is within the setpoint.
- If any one of the three conditions shows "CHK SENSOR" then that condition will be treated as always FALSE.

Boolean Relay Logic Operations

(a | b | c) means
"Activate this relay when either
a OR b OR c is true."

Relay 1 Operator
(a | b | c) >

Relay 1 Operator:
(a & b & c) >

(a & b & c) means
"Activate this relay only when
a AND b AND c are all true."

(a | (b & c)) means
"Activate this relay if a is true
OR if b AND c are both true."

Relay 1 Operator:
(a | (b & c)) >

Relay 1 Operator:
(a & (b | c)) >

(a & (b | c)) means
"Activate this relay only if a is true
AND either b or c are also true."

Program a Relay for Advanced Operation

Example: Set Relay #1 to activate IF pH3 falls below 5, OR if pH4 rises above 8.5, OR if Level L6 rises above 18 inches. Relay #1 will activate 30 seconds after any one the conditions are met.

- Condition a: The pH on Channel 3 is less than 5.
Condition b: The pH on Channel 4 is greater than 8.5
Condition c: The Level on Channel 6 is greater than 18.

When operating properly, all three of these conditions are FALSE. If any one of them becomes TRUE, then Relay 1 will be activated. Relay 1 will remain activated until the TRUE condition becomes FALSE again, including the hysteresis band.

Relay 1 Source:
Flow F1 >

1. Starting from normal operation (View mode), Press and hold the ENTER key for 2 seconds to jump to the Menu Directory. Press the DOWN key three times to scroll to the RELAY menu then press ENTER key.

Relay 1 Source:
Multiple >

2. Use the keypad to navigate through the Relay menu. Set the relay Source to "Multiple" and set the Relay mode to "Advanced."

Relay 1 Mode:
Advanced >

Relay 1 Operator
(a | b | c) >

3. Select the Relay Operator that represents the set of conditions. In this example that is (a | b | c).

Relay 1 Source1:
pH3 >

Relay 1 Source2:
pH4 >

Relay 1 Source3:
Level L6 >

Relay 1 Mode 1:
Low >

Relay 1 Mode 2:
High >

Relay 1 Mode 3:
High >

4. Set up to three sources for the Relay, assign a Mode to each source (High, Low or Off) Set a Setpoint and Hysteresis for each source.

Relay 1 Setpnt1:
5.00 pH >

Relay 1 Setpnt2:
8.50 pH >

Relay 1 Setpnt3:
+18.00 in >

Relay 1 Hys 1:
0.5 pH >

Relay 1 Hys 2:
0.5 pH >

Relay 1 Hys 3:
1.00 in >

Relay 1 Delay:
30.00 secs >

5. Set a relay delay time if applicable.

When all relay parameters are set, press the UP and DOWN keys together to exit from the Relay menu back to the Menu Directory, then press the same keys again to exit from the Menu Directory back to normal operation.

12. Output

Output 1 Source: Flow 1 >	Select measurement type or derived function to be assigned to this output.
Output 1 Range: 0-5Vdc >	If I/O Module with Voltage Output is installed: Select 0-to-5 VDC or 0-to-10 VDC .
Output 1 0Vdc: +25.000 GPM >	If I/O Module with Voltage Output is installed: Enter the low-end setpoint = 0 VDC.
Output 1 5Vdc: +25.000 GPM >	If I/O Module with Voltage Output is installed: Enter the high-end setpoint = 5 or 10 VDC.
Adjust 1 Low: 0 V >	Adjust the output voltage at low-end setpoint: 0 to 0.5 VDC.
Adjust 1 High: 5 V >	Adjust the output voltage at high-end setpoint: 4.5 to 5.5 VDC or 9.5 to 10.5 VDC.
Output 1 4mA: +25.000 GPM >	If Current output card is installed: Set the low-end setpoint = 4 mA.
Output 1 20mA: +25.000 GPM >	If Current output card is installed: Set the high-end setpoint = 20 mA.
Adjust 1 Low: 4.00 mA >	Adjust the output current at low-end setpoint: 3.8 to 5.0 mA.
Adjust 1 High: 20.00 mA >	Adjust the output current at high-end setpoint: 19.0 to 21.0 mA.
Test Output 1: >	Manually adjust analog output to test operation. If 4 to 20 mA, test limits are 3.8 mA to 21.0 mA . If 0 to 5 VDC, test limits are 0.00 to 5.50 VDC . If 0 to 10 VDC, test limits are 0.00 to 10.50 VDC .

13. Calibration

13.1 Calibration: If Channel type = Flow

Volumetric calibration

Select VOLUMETRIC CALIBRATION if the flow rate can be determined by filling a vessel of known volume. The 8900 will count the number of pulses generated as the known volume of fluid passes through the sensor, and then use the information to calculate a K-Factor.

F1 Cal Method: Volume >	Select to perform volumetric calibration.
Press <ENTER> to Start Cal	Press ENTER to start the volumetric calibration period. The 8900 starts counting pulses from the flow sensor.
Press <ENTER> to Stop Cal	Press ENTER to stop the volumetric calibration period. The 8900 stops counting pulses from the flow sensor.
Enter Volume: 0000.0 GPM	Enter the volume of fluid known to have flowed past the sensor during the volumetric calibration period. This will modify the existing Flow K-Factor.
New K-Factor: 12.345	Successful volumetric calibration. Press ENTER to accept the new K-Factor or press UP-DOWN keys simultaneously to escape without saving and return to Enter Volume.
Error: K-Factor Out Of Range	The calculated K-Factor is less than 0.0001 or greater than 99999. Returns to Enter Volume.
Error: No Flow Detected	Indicates that the flow sensor is not generating any pulses, or pulses are not detected by the 8900. Returns to Volumetric Cal.

Rate-based calibration

Select RATE CALIBRATION to match the dynamic flow rate to an external reference. Entering a rate will modify the existing K-Factor.

F1 Cal Method: Rate >	Select to perform rate calibration.
F1 Rate Cal: >	Press RT ARROW to start the rate calibration.
F1 Rate Cal: 0.0000 GPM	Use the keypad to set the flow rate in the flashing display to match the reference meter. Press ENTER when completed.
Error: K-Factor Out Of Range	The calculated K-Factor is less than 0.0001 or greater than 99999. Returns to Rate Cal >.

13.2 Calibration: If Channel type = pH

pH1 Cal at:
Sensor >

SENSOR: Select to perform calibration at the sensor via 2750 EasyCal.
INSTRUMENT: Select to perform calibration at the 8900 via the steps below.

If Cal at Instrument is selected, the following menu items appear:

Set pH1 Std:
>

Place sensor in any pH buffer. Allow sufficient time for sensor output to stabilize, then enter value. Maximum offset allowed: ± 1.3 pH.

Set pH1 Slope:
>

Place sensor in any buffer that is different by at least 2 pH units from Std value, then enter value. Maximum offset allowed: ± 1.3 pH.

Set Temperature
T1: >

Adjust the temperature measurement from the pH sensor to match a reliable reference. Maximum offset allowed is ± 20 °C

Reset pH1 to
Factory Cal: >

If pH~ Cal at Instrument is selected, reset Standard, Slope and Temperature to factory calibration.

13.3 Calibration: If Channel type = ORP

ORP1 Cal at:
Sensor >

SENSOR: Select to perform calibration at the sensor via 2750 EasyCal.
INSTRUMENT: Select to perform calibration at the 8900 via the steps below.

If Cal at Instrument is selected, the following menu items appear:

Set ORP1 Std:
>

Place sensor in any ORP test solution. Allow sufficient time for sensor output to stabilize, then enter value. Maximum offset allowed: ± 2900 mV.

Set ORP1 Slope:
>

Place sensor in any buffer that is different by at least 30 mV from Std value, then enter value. Maximum offset allowed: ± 2900 mV.

Reset ORP1 to
Factory Cal: >

If ORP~ Cal at Instrument is selected, reset Standard and Slope to factory calibration.

13.4 Calibration: If Channel type = Conductivity

**C1 Cal at:
Sensor >**

SENSOR: Select to perform calibration at the sensor via 2850 EasyCal.
INSTRUMENT: Select to perform calibration at the 8900 via the steps below.

If Cal at Instrument is selected, the following menu items appear:

**Set Conductivity
C1: >**

Place sensor in any conductivity test solution. Allow sufficient time for sensor output to stabilize, then enter value.

**Set Temperature
T1: >**

Adjust the temperature measurement from the conductivity sensor to match a reliable reference. Maximum offset allowed is ± 20 °C

**Reset C1 to
Factory Cal: >**

If C~ Cal at Instrument is selected, reset Conductivity and Temperature to factory calibration.

13.5 Calibration: If Channel type = Pressure

**Set Zero
P2: >**

Select YES to set reading to zero at ambient atmospheric pressure.
Maximum offset allowed is ± 2.75 psi.

**Set Pressure
P2: >**

Adjust the pressure to match a reliable reference.
Must be ≥ 3 psi above zero point.
Maximum offset allowed is ± 2.75 psi.

**Reset P2 to
Factory Cal: >**

Reset the pressure calibration to factory setting.

13.6 Calibration: If Channel type = Temperature

**Set Temperature
T2: >**

Adjust the temperature to match a reliable reference.
Maximum offset allowed is ± 20 °C.

**Reset T2 to
Factory Cal: >**

Reset Temperature to factory calibration.

13.7 Calibration: If Channel type = Level

**Set Level
L1: >**

Enter the level value (in inches) based on an external measurement.

**Reset L1 to
Factory Cal: >**

Reset level calibration to factory setting.

14. Options

Password Type: Standard	The standard password is "UP-UP-UP-DOWN" Select Enhanced password to set a custom 4-digit code.
Select Enhanced Password >	If "Enhanced" password is selected, set any 4-digit numerical code: 0000 (default) to 9999. If the enhanced password is lost, see section 14.1 below.
Contrast: 3 >	Adjust LCD contrast: 4 settings.
Auto Scroll: Off >	Enable Auto Scroll for measurement Display screens in View.
Scroll Time: 4 secs >	Set the scroll time interval for each measurement display screen. Minimum 1 second, maximum 99 seconds. Press any key to interrupt autoscroll for 20 seconds, or the scroll time, whichever is greater.
Func. 1 Type: Ratio >	If two or more measurements of the same type are present, select a functional relationship between them: Sum Difference Ratio % Reject % Passage % Recovery (A, B, or C) Power 2 Power 4 None
Func. 1 Source: ORP1-ORP2 >	Select the two measurements to be used for this function.
Clone Port: S3L >	Select the type of data transfer you will use to clone the setup from one 8900 into another. Refer to Appendix E for detailed instructions. Digital (S ³ L) or COMM.
Clone Operation: Send >	Select whether this 8900 will send setup information to another unit, or will receive the setup from another unit. SEND or RECEIVE.
Clone Instrument: >	Select "YES" to begin clone process.
Memo: gfsignet.com >	Enter notes such as: next commissioning date, scheduled service, Tech Support telephone number, etc.
Clear Memo? >	Completely clears any characters in the MEMO field.
Choose language: English >	Change the language for all menus in the 8900. Options are: English, Italian, German, French, Spanish, Portuguese
Separator: . >	Select "." (Decimal point) or "," (Comma) to separate fractional portion of values. Example: 123.45 or 123,45

14.1 Password Security

The standard password is the UP-UP-UP-DOWN keys, pressed in sequence. This access code is designed to protect the 8900 from unintentional changes. It is best suited for systems where a group of people need to be able to change settings.

Enhanced Password

The enhanced password default setting is 0-0-0-0, adjustable to any 4-digit numerical code up to 9999. Using a personal password provides the maximum degree of security.

Enhanced Password Reset Procedure:

The following procedure will reset the Enhance Password to the factory default code of (0-0-0-0).

1. Disconnect power.
2. Remove the I/O Module (remove terminals from this and all other plug-in modules installed, then the rear cover).
3. Cycle power to the unit (apply power for at least 15 seconds, then disconnect power again)
4. Install the I/O Module, the rear panel, and terminals as applicable.
5. Reconnect power to the unit.

Appendix A: Derived Functions

When two or more measurements of the same type are present, the 8900 can calculate several derived functions from like pairs. Up to three derived Functions can be defined and used as the source for display and output functions.

- Flow, Temperature, Pressure, and Level channels must have matching units. (flow channels must also have same timebase)
- Conductivity channels will automatically scale to $\mu\text{S}/\text{cm}$ before the function calculation is made.
- **Three derived measurements can be applied to any set of sensors, regardless of type.**
 - Ratio: Measurement 1 \div Measurement 2
 - Difference: Measurement 1 - Measurement 2
 - Sum: Measurement 1 + Measurement 2

% Passage and % Reject

- % Passage and % Reject are derived from conductivity measurements only, specifically for use in reverse osmosis systems.
- % Passage is the amount of contaminates remaining in the product water compared to the level of contaminates in the feed water. For example, if the feed water measures 100 μS and the product water measures 5 μS , the % Passage is $(5 \div 100) \times 100$, or 5%.
- % Reject is the amount of contaminates rejected to the concentrate water compared to the amount of contaminates in the feed water. For example, if the % Passage is 5%, the % Reject is 95%.
- Decreasing Reject values and increasing Passage values usually indicate a problem with the RO membrane.

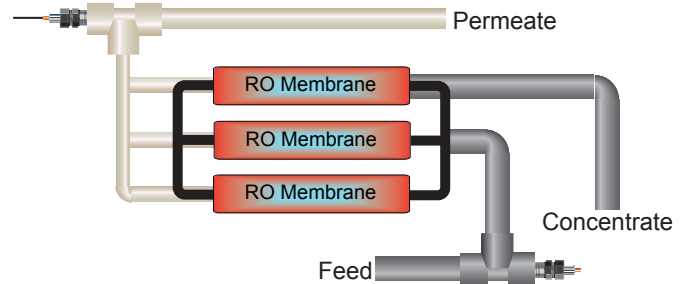

% Passage: $(\text{Permeate} \div \text{Feed}) \times 100$

% Reject: $[1 - (\text{Permeate} \div \text{Feed})] \times 100$

% Recovery

- % Recovery is a derived measurement based on flow rate only. In a reverse osmosis system, % Recovery is flow rate in the permeate (product) compared to the flow rate of the incoming feed water.
- To measure % Recovery, the 8900 must have two flow sensors connected. They may be located in the Feed line, the Concentrate line or the Permeate line.
- The 8900 provides 3 different methods for calculating Recovery to accommodate any configuration.
- Both flow sensors must use the same timebase and units of measure.

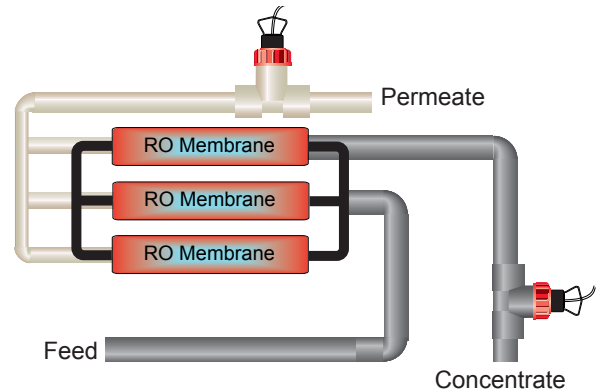

% Recovery B: $\text{Permeate} \div (\text{Permeate} + \text{Concentrate}) \times 100$
In the Setup menu, select the option that represents **Concentrate** \oslash Permeate

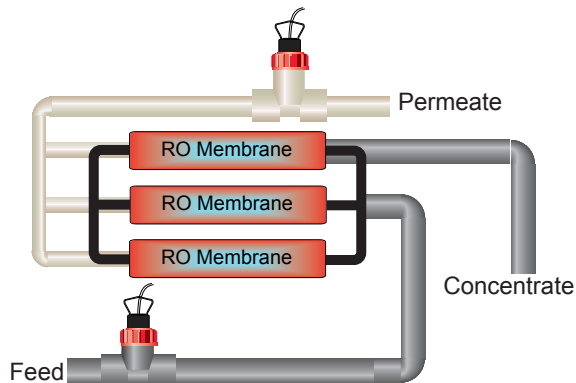

% Recovery A: $(\text{Permeate} \div \text{Feed}) \times 100$
In the Setup menu, select the option that represents **Feed** \oslash Permeate

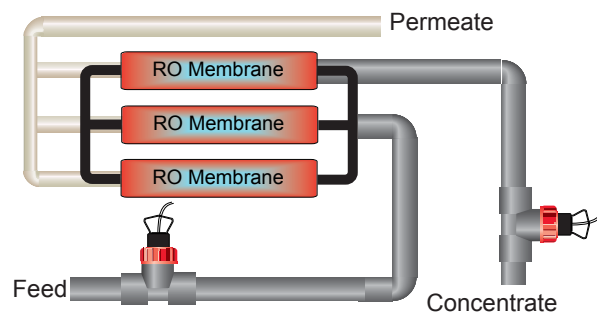

% Recovery C: $[(\text{Feed} - \text{Concentrate}) \div \text{Feed}] \times 100$
In the Setup menu, select the option that represents **Concentrate** \oslash Feed

Appendix B: Level System Configuration

The Signet 2450 Pressure sensor can be used to calculate level values. The following information is required for this mode:

1. Determine where you want the level measurement to start. This is the Zero reference point (Z).
Review the diagrams for your sensor type to help select the best option.
2. Determine where you will mount the sensor. This is S_{Loc} .
Consult the Sensor manual for information regarding the best location for the sensor.
3. Measure the distance between Z and S_{Loc} . This is **O(ffset)**.
4. Enter the Offset into the Calibrate menu.

Zero reference point (Z):

Definition:

The point in the vessel where you want the 8900 to display zero (0 ft, 0 gal. etc).

- If Z is located below the fluid surface, the 8900 will display a positive level measurement.
- If Z is located above the fluid surface, the 8900 will display a negative level measurement.

Sensor Location point (S_{Loc}):

Definition:

The point on the level sensor where the measurement is taken.

- Pressure sensors measure from the centerline of the diaphragm.

Offset (O):

Definition:

The distance from the zero reference point (Z) to the sensor location point (S_{Loc}).

- Enter a positive value in the Calibrate menu if the sensor is located above Z (zero reference point).
- Enter a negative value in the Calibrate menu if the sensor is located below Z (zero reference point).
- Enter 0 in the Calibrate menu if the sensor is located at Z (zero reference point).

Level (L):

Definition:

- The distance from Z (zero reference point) to surface of fluid.

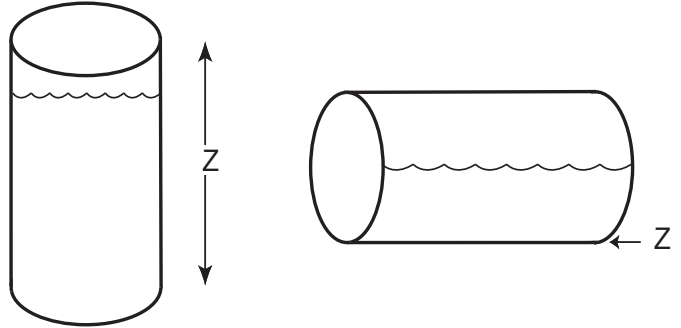

For most vessels, the zero reference point may be designated as any height in the vessel.

For horizontal cylinders only, the zero reference point MUST be the lowest point in the vessel.

2450 Pressure Sensor Location and Offset

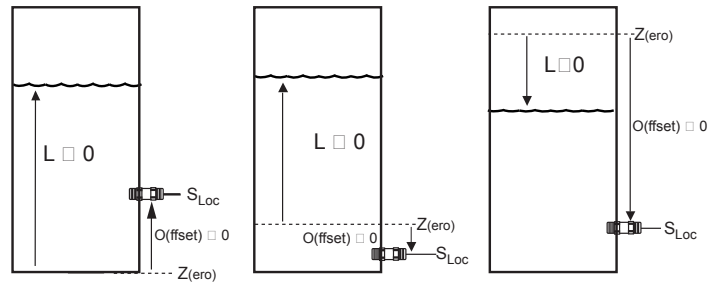

Level and Volume conversion in custom shaped vessels

If you select Custom Shape in the Options menu, you can define from 2 to 20 Custom Points to establish the relationship of level to volume in the vessel.

- Select Manual level Measurement mode to edit both level and volume data (dry configuration).
- Select Automatic level Measurement mode to accept the sensor measurement of the Level, while you assign a volumetric value to each custom point (wet configuration).
- Enter from 2 to 20 custom points to link level and volume values.
- The first custom point must be the lowest fluid level in the vessel.
- Each successive point must be greater than the preceding point.
- The last point must be equal to or greater than the highest fluid level in the vessel.
- A custom point should be located at all transition points in the vessel shape (for example, at custom point #9, where the shape changes from a cylinder to a cone).
- The more complex sections should be defined with more points. Notice that the conical section of the illustration has been defined by custom points 1 through 9.
- Simpler sections require fewer defining points. Note that the cylinder requires only custom points 9 and 10.

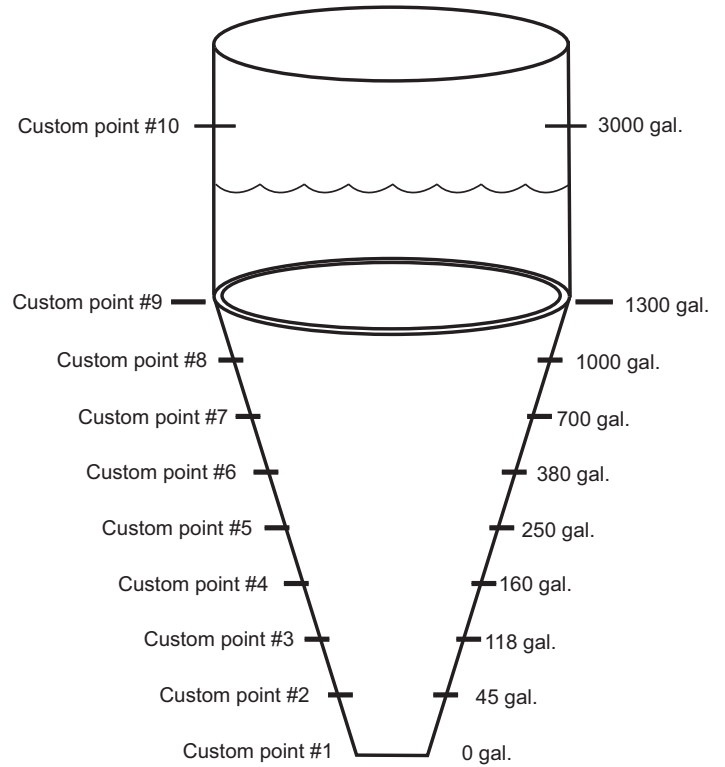

Custom vessel:
The 8900 performs linear interpolation between adjacent points.

Technical Reference for Level measurement

Level, volume and mass calculations performed by the 8900 include:

Pressure to level conversion:

$$\text{Level} = P \div (SG \cdot D_{(water)})$$

where P = Pressure
SG = Specific Gravity of fluid
 $D_{(water)}$ = Density of water

With pressure in psi: Level (meters) = $(0.703069 \cdot P / SG)$

with pressure in bar: Level (meters) = $1.019715 \cdot P / SG$

Mass conversion

$$m = D_{(water)} \cdot SG \cdot V$$

where m = mass of fluid
 $D_{(water)}$ = Density of water = 1000 kg/m³
SG = Specific Gravity of fluid
V = Volume of fluid (m³)
 $m \text{ (kg)} = 1000 \cdot SG \cdot V$

Volume calculations

Vertical cylinder: $V = \pi \cdot d^2 \cdot h / 4$

where d = diameter of cylinder
h = height of fluid

Rectangular vessel: $V = w \cdot l \cdot h$

where w = width
l = length
h = height

Horizontal cylinder: $V = A \cdot L$

where A = area of segment
L = Length of vessel
r = radius of vessel
h = height of segment

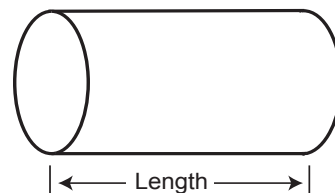
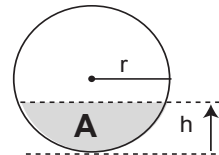

Appendix C: Conductivity/Resistivity Application

Temperature Effects

Conductivity measurement is highly dependent on temperature. The basic rule is that higher temperatures result in greater conductance (less resistance).

Temperature effects are expressed as the percentage of conductivity change (in μS) per $^{\circ}\text{C}$. The conductivity value is generally referenced to 25°C . The 8900 has three temperature compensation options:

None

USP standards for pharmaceutical waters require that the measurement be made without temperature compensation. USP limits are discussed in Appendix D.

Pure Water (Standard Compensation)

This selection is used for measurements of very clean water, less than $0.2\ \mu\text{S}$. Temperature effects are not linear in this range, so the temperature coefficient is not easily determined. This selection is recommended for all Resistivity applications measuring from $5\ \text{M}\Omega$ to $18\ \text{M}\Omega$. This selection conforms to ASTM standard D1125 and D5391.

Linear

This selection allows you to calculate a custom temperature compensation value for Conductivity measurements in the range of $0.2\ \mu\text{S}$ and greater (Resistivity applications measuring less than $5\ \text{M}\Omega$). The procedure is outlined in the section on the right.

TDS Factor

Some industries need to display a conductivity value as Total Dissolved Solids (TDS), measured in units of parts per million (PPM) or parts per billion (PPB).

- 1 PPM is equivalent to 1 mg per liter.
- 1 PPB is equivalent to $1\ \mu\text{g}$ per liter.
- The 8900 calculates PPM or PPB by dividing the μS value by a TDS Factor that you define.
- TDS factors can vary widely, ranging from 1.50 to $2.50\ \mu\text{S}$ per PPM. Methods for establishing a TDS factor are beyond the scope of this manual.
- The 8900 will accept TDS factor values from 0.01 to $99999.9\ \mu\text{S}$ per PPM.
(factory preset = $2.00\ \mu\text{S}$ per PPM)

NOTE: The 8900 TDS factor must be set in PPM.

TDS Factor = Conductivity (μS) \div Total dissolved solids (PPM)

PPM = Solution conductivity (μS) \div TDS Factor

Example:

- Solution conductivity = $150\ \mu\text{S}$
- TDS = $80\ \text{PPM}$
- TDS Factor = $150\ \mu\text{S} \div 80\ \text{PPM} = 1.88\ \mu\text{S per PPM}$

Calculating a Linear Temperature Coefficient

1. Set TC Mode to NONE (see SETUP menu).
2. Heat a sample solution close to the maximum process temperature. Place sensor in the sample solution and allow several minutes for stabilization. Record the 8900 temperature and conductivity values in the spaces provided:

Displayed temperature: T1 = _____ $^{\circ}\text{C}$

Displayed conductivity: C1 = _____ μS

3. Cool the sample solution close to the minimum process temperature. Place sensor in the sample solution allowing several minutes for stabilization. Record displayed temperature and conductivity values in the spaces provided:

Displayed temperature: T2 = _____ $^{\circ}\text{C}$

Displayed conductivity: C2 = _____ μS

(A 10% change in conductivity between steps 2 and 3 is recommended.)

4. Substitute recorded readings (steps 2 and 3) into the following formula:

$$\text{TC Slope} = \frac{100 \times (C1 - C2)}{(C2 \times (T1 - 25)) - (C1 \times (T2 - 25))}$$

Example: A sample solution has a conductivity of $205\ \mu\text{S}$ @ 48°C . After cooling the solution, the conductivity was measured at $150\ \mu\text{S}$ @ 23°C . ($C1 = 205$, $T1 = 48$, $C2 = 150$, $T2 = 23$)

The TC is calculated as follows:

$$\text{TC Slope} = \frac{100 \times (205 - 150)}{(150 \times (48 - 25)) - (205 \times (23 - 25))} = \frac{5500}{3860} = 1.42\%/^{\circ}\text{C}$$

Conductivity Calibration Procedure

Wet Calibration with NIST Traceable Solutions:

- When using NIST traceable standards, review the temperature information provided with the test solution.
- Prevent contamination of the test solution.
- The sensor must be at the temperature specified on the test solution label.
- Remove the sensor from the system and rinse in a small amount of test solution.
- Place the sensor into the test solution. Gently stir/shake the electrode to dislodge any air bubbles on the electrode.
- Place a reference thermometer into the same solution.
- Allow sufficient time for the temperature to stabilize.
- Set Temp: Adjust the temperature value based on the reference thermometer.
- Set Cond: Adjust the conductivity value based on the test solution value.
- Verify the linearity of the 8900 by placing the sensor into a second test solution of a different value.
- If the 8900 does not display the correct value (Temperature $\pm 0.5^{\circ}\text{C}$, Conductivity $\pm 2\%$ of reading), service is required.

Appendix D: USP Limits

USP (United States Pharmacopoeia) has defined a set of conductivity values (limits) to be used for pharmaceutical water. The standard requires that conductivity measurement without temperature compensation be used for these applications. The limits vary according to the temperature of the sample. The 8900 has the USP limits stored in memory. It will automatically determine the proper USP limit based on the measured temperature.

Using the USP function

USP setpoints are defined as a percentage below the USP limit, so a USP alarm is always a HIGH alarm. The 8900 can be set to warn you if the conductivity approaches within a set percentage of the USP limit.

The following settings and conditions are required for a USP relay function:

1. In the Setup menu:

- RELAY MODE must be set to USP.
- RELAY SOURCE must be a Conductivity channel
- SOURCE UNITS must be set to μS .

2. In the OPTIONS menu:

- The TC Mode of the USP channel must be set to **None**.

(If a relay is constantly on when it should be off, check relay settings listed above.)

Example:

- The USP setpoint is 40%.
- The water temperature is 19 °C, so the USP limit is 1.0 μS .
- The relay will be activated when the conductivity value reaches 0.6 μS , or 40% below the 1.0 USP limit.
- If the water temperature drifts to more than 20 °C, the 8900 will automatically adjust the USP limit to 1.1.
- The relay will now be activated when the conductivity value reaches 40% below 1.1 μS , or 0.66 μS .

When the temperature range is:	The USP limit (μS) is:
0 °C to < 5 °C	0.6 μS
5 °C to < 10 °C	0.8 μS
10 °C to < 15 °C	0.9 μS
15 °C to < 20 °C	1.0 μS
20 °C to < 25 °C	1.1 μS
25 °C to < 30 °C	1.3 μS
30 °C to < 35 °C	1.4 μS
35 °C to < 40 °C	1.5 μS
40 °C to < 45 °C	1.7 μS
45 °C to < 50 °C	1.8 μS
50 °C to < 55 °C	1.9 μS
55 °C to < 60 °C	2.1 μS
60 °C to < 65 °C	2.2 μS
65 °C to < 70 °C	2.4 μS
70 °C to < 75 °C	2.5 μS
75 °C to < 80 °C	2.7 μS
80 °C to < 85 °C	2.7 μS
85 °C to < 90 °C	2.7 μS
90 °C to < 95 °C	2.7 μS
95 °C to < 100 °C	2.9 μS
100 °C to < 105 °C	3.1 μS

Appendix E: Cloning using Digital (S³L) (Serial Cloning)

Cloning enables copying the programming from one unit into another unit. After one 8900 is completely programmed, it becomes a Master (SEND) unit that can download its settings to a Slave (RECEIVE) 8900.

Step 1: Controller Designations

1. Designate the 8900 controller that will receive the data and refer to this controller as the Receiving Controller.
2. Designate the other 8900 controller as the Transmitting Controller.

Step 2: Wiring

1. Connect terminal 9 of both controllers together with a single wire conductor.
2. Connect terminal 10 of both controllers together with a single wire conductor. See Figure 1.

Step 3: Configure the Receiving Controller

1. Go to the Option menu and scroll until you see the "Clone Port" menu item and set the selection to "S³L", if not already set.
2. Scroll down to the "Clone Operation" menu item and set it to "Receive", if not already set.
3. Scroll down in the Option's menu until you see the menu item "Clone Instrument".
4. Press the right arrow key to toggle the selection choices.
5. Press the ENTER key, when the "Yes" selection is flashing, to proceed.
6. The message "All Settings Will be Changed" will be displayed for about 3 seconds.
7. The message "Are You Sure?" will be followed by the previous message and will also be displayed for about 3 seconds.
DO NOT press the ENTER key yet.
8. The Receiving Controller is now ready to start the cloning process, but the Transmitting Controller must also be configured to start the cloning process. Proceed to Step 4.

Transmitting Controller

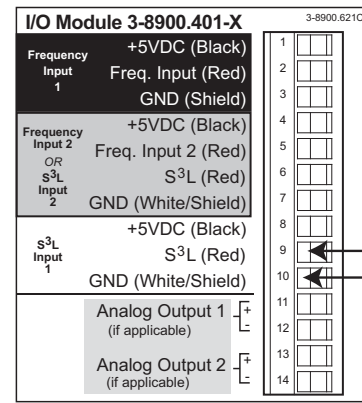

Receiving Controller

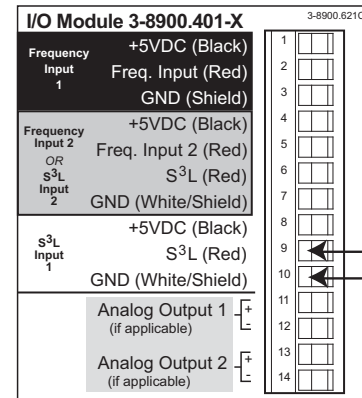

Figure 1

Clone
Instrument: >

All Settings
Will be Changed!

Are You Sure?
Press <ENTER>

Step 4: Configure the Transmitting Controller

1. Now go to the Transmitting Controller's Option menu and scroll until you see the "**Clone Port**" menu item and set the selection to "**S3L**", if not already set.
2. Scroll down to the "**Clone Operation**" menu item and set it to "**Send**", if not already set.
3. Scroll down in the Option menu until you see "**Clone Instrument**".
4. Press the right arrow key to toggle the selection choices.
5. **Do not press the ENTER key yet.**

Clone
Instrument: >

Step 5: Start and Finish Cloning Process

1. TIP: Due to timing constraints, please read through steps 2 thru 6 below before actually executing them.
2. Place the two 8900 controllers near each other and press the ENTER key on the Transmitting Controller. The message "**Waiting for Request**" should be displayed.
3. Go to the Receiving 8900 controller and press the ENTER key. (**NOTE: This step must occur within 7 seconds of the previous step**). You should see the following message displayed "**Requesting Data From Host**":
4. The message "**Transmitting Data**" is shown on the Transmitting Controller's display while data transfer is in progress. The display on the Receiving Controller will remain the same as in step 3 above.
5. When the following message "**Transfer Complete**" is displayed on both controllers, the cloning process was successful. Otherwise, the cloning process failed and you should see the following message, "Transmitting Data" displayed on the Transmitting Controller. You should also see " Error: No Data From Host" displayed on the Receiving Controller's display.
6. In either case, press the right arrow key and both 8900 controllers will restart and the Receiving controller configuration settings will be adopted if the cloning operation was successful.

Waiting for
Request...

Requesting Data
From Host

Transmitting
Data...

Transfer
Complete >

Transmitting
Data...

Error: No Data
From Host >

Appendix F: BTU Quick Start Guide

This guide outlines how to configure the 8900 Multi-Parameter to calculate Power and Energy. There are some limitations that must be known and requirements that must be adhered to in order for the calculation to work properly.

The user can select power units, energy units, can show only the heating totalizer, show only the cooling totalizer or show both. The heating and cooling totalizers are all permanent totalizers. The user can also enter the fluid density and heat capacity to obtain higher accuracy. The power measurements can be used as a relay source to control alarms or as a source for a 4 to 20 mA output.

Quick Setup Configuration

1. In the System Setup Menu:

- Assign a FLOW channel to Channel 1 or Channel 4.
(IMPORTANT: must be these channels only)
- Assign two TEMPERATURE channels.
If FLOW is on channel 1, then TEMPERATURE must be on channels 2 and 3.
If FLOW is on channel 4, then TEMPERATURE must be on channels 5 and 6.
(The examples on this page depict the use of channels 1, 2 and 3. For a second Power measurement, assign Flow to channel 4 and Temperature to channels 5 and 6.)

Channel 1 Type:
Flow >

Channel 2 Type:
Temperature >

Channel 3 Type:
Temperature >

2. In the Channel Settings Menu:

- Set the Flow Units to one of the following (the timebase can be set at any value).
- The units MUST BE EXACTLY AS ILLUSTRATED.

G or g	U.S. Gallons	(examples: GPM, G/H, gpm, etc.)
GU or gU	Imperial Gallons	(examples: GU/m, gU/h, GU)
L or l	Liters	(examples: _L/m, _LPM, _l/h)
mL or ml	Milliliters	(examples: mL/s, ml/m)
CF or cf	Cubic Feet	(examples: CF/h, cf/d, CFPD)
M3 or m3	Cubic Meters	(examples: M3/h, m3/d, m3/h)

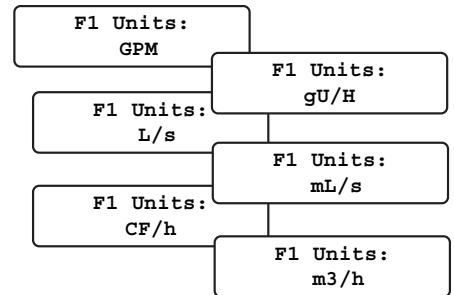

- Select the units for the two TEMPERATURE channels to °C or °F.
- BOTH TEMPERATURE CHANNELS MUST BE SET TO THE SAME UNITS.
- If the Temperature units are set to °C, Density units are fixed at kg/m³.
Heat Capacity Units are fixed at kJ/kg·K.
- If the Temperature units are set to °F, Density units are fixed at lbs/ft³.
Heat Capacity Units are fixed at BTU/lbs·°F

T2 Units:
°C >

T3 Units:
°C >

3. In the Options Menu:

Func. 1 Type: Diff >	Set Function 1 to operate as a differential measurement.
Func. 1 Source: Diff T2-T3 >	Select T2-T3 as the source for the Differential measurement. <ul style="list-style-type: none"> To switch from heating to cooling mode, just change the order of the Delta Temperature Sources. For example: Change the "Func. 1 Source" from "Diff T2 – T3" to "Diff T3 – T2".
Function 2 Type: Power 2 >	Set Function 2 to operate as Power 2
Power 2 Flow: F1 >	Select Flow Channel 1 as the flow measurement used in the calculation of Power 2. Default is the first flow channel assigned.
Power 2 Unit: kW >	Select power unit: Choose: J/s, W, kW, BTU/m, BTU/h, kBTU/h. Default is kW.
Energy 2 Unit: kWh >	Select energy unit: Choose: J, kJ, MJ, GJ, kWh, MWh, BTU, kBTU, MBTU. Default is kWh.
Heat Capacity 1: 4.1840 kJ/kg·K >	Select heat capacity value. Default is 4.1840 kJ/kg·K
Density 2: 999.97 kg/m ³ >	Select the density of the liquid. If the Temperature units are set to °C, Density units are fixed at kg/m ³ . Factory setting is 999.97 kg/m ³ .
Energy 2 Total: Show Both >	Choose: Show Cooling, Show Heating, or Show Both. Default is Show Both. <ul style="list-style-type: none"> If the Diff T2 – T3 value is positive, the heating totalizer will be incremented. If the Diff T2 – T3 value is negative, the cooling totalizer will be incremented.

Appendix G: 8900 display messages

The 8900 communicates with the user to notify when something is wrong, and to inform of tasks underway. This appendix lists all of the messages that may appear during operation, and describes the purpose of the message.

This is the title screen when the unit is powered on.	8900 Multi-Parameter	Too Much Error CHECK SENSOR	The calibration offset is limited in most measurements. The adjustment entered exceeds the maximum value.
This message is displayed after saving a new selection for a menu item.	Saving	Must Have More Than 1 Point	These messages refer to the points required to calculate the volume when choosing a custom volume tank shape. (3 minimum, 20 maximum)
This is displayed when going from any submenu to the main menu directory.	Returning to Menu Directory	Must Have 20 or Fewer Points	
This is displayed when going from the main menu directory to the view mode.	Returning to ViewMode...	WARNING! Table Must Be Modified	When a change is made to the custom volume points, this message is displayed.
If "Password Type" is set to "Standard."	Enter Password: _ _ _ _	Channel 6 Custom Table Error	One or more points in the table are not in sequence.
If "Password Type" is set to "Enhanced."	Enter Password: 0000	Must Be > Than Previous Point	Each custom volume point must be greater than the previous point.
This is displayed when the wrong password is entered.	Invalid Password Try Again	No Relay Cards Installed	Self explanatory.
Warning messages are displayed when a channel type is changed.	Channel Data Will be RESET!	No Output Cards Installed	Self explanatory.
	Check Relay And Output Sources	No Input Card Installed	Self explanatory.
If trying to enter the "Calibration" menu when no channel types are selected.	Channel Type Must Be Selected	Channel Type Must Be Selected	Self explanatory.
Indicates a faulty sensor connection or a channel with no sensor assigned.	pH3 CHK SENSOR T4 CHK SENSOR	Memory Error Load Defaults??	Displayed if the memory in the 8900 is corrupted.
The 8900 advises when a value is outside of the range allowed.	Value Must Be 6400 or Less	Loading Factory Settings...	Message displayed if Load Defaults is selected.
	Value Must Be 100.0 or Less	Channel 1 ID: No Valid Sensors	The 8900 finds no sensors matching the channel type.

A sensor is connected but has not been assigned to a channel	Channel 1 ID: Not Assigned?	Value Must Be 0.05 Or Higher	Relay pulse width is 0.05 ms minimum, 1000 ms maximum
Self explanatory.	Input Module Not Found	Value Must Be 1000.0 Or Less	
These messages indicate component failure on the Comm or I/O module.	Input/Output 1&2 Module Defective	Value Must Be 14.00 Or Less	In pH calibration, the buffers cannot exceed 14 pH in value.
	Comm/Out 3&4 Module Defective	All Settings Will Change!	When cloning the setup from a host unit into a slave unit, these messages warn of impending actions and verify that the change is intentional.
Pressure calibration cannot be done at zero.	Cal Point Too Close to Zero	Are You Sure? Press <ENTER>	
pH calibration buffers must be at least 2 pH units apart.	Standard Too Close to Slope	Requesting Data From Host	Slave unit is transmitting request for data download from the host unit.
Messages displayed when "LOAD S ³ L DEVICES" is selected.	6 Sensors and 1 Ext Relay	Waiting For Request...	Host unit is waiting for the slave to request data download.
	Loading... Please Wait	Error:Invalid Host Version	If the host and slave units have incompatible software versions.
	Found New S3L Devices	Error:No Data From Host	Host unit is not transmitting to the slave.
If a relay is in PWM mode, the period must be greater than 0.1 seconds, and less than 3240 seconds.	Value Must Be 3240 Or Less	Error: Data Transfer Failed	Self explanatory.
	Value Must Be 0.1 Or Higher	Transmitting Data...	Self explanatory.
If a relay is in Proportional Pulse mode, the minimum pulse rate is 1, the maximum rate is 400.	Value Must Be 1 Or Higher	Transfer Complete	Self explanatory.
	Value Must Be 400 Or Less	8900 Restarting	Self explanatory.

Ordering Information

Mfr. Part No.	Code	Description
Base Unit, required; choose one		
3-8900	159 000 868	Base unit with back-lit LCD
I/O Module, required; choose one		
3-8900.401-1	159 000 870	Two inputs, no outputs
3-8900.401-2	159 000 871	Two inputs, two passive 4 to 20 mA outputs
3-8900.401-3	159 000 872	Two inputs, two active 4 to 20 mA outputs
3-8900.401-4	159 000 873	Two inputs, two 0 to 5/10 VDC outputs
3-8900.401-5	159 000 874	Four inputs, no outputs
3-8900.401-6	159 000 875	Four inputs, two passive 4 to 20 mA outputs
3-8900.401-7	159 000 876	Four inputs, two active 4 to 20 mA outputs
3-8900.401-8	159 000 877	Four inputs, two 0 to 5/10 VDC outputs
3-8900.401-9	159 000 968	Six inputs, no outputs
3-8900.401-10	159 000 969	Six inputs, two passive 4 to 20 mA outputs
3-8900.401-11	159 000 970	Six inputs, two active 4 to 20 mA outputs
3-8900.401-12	159 000 971	Six inputs, two 0 to 5/10 VDC outputs
Power Module, required; choose one		
3-8900.402-1	159 000 878	85 to 264 VAC power
3-8900.402-2	159 000 879	12 to 24 VDC power
Relay Module, optional; choose zero, one or two		
3-8900.403-1	159 000 880	Two dry-contact relays
3-8900.403-2	159 000 881	Two solid-state relays
External Relay Module, optional; choose zero or one		
3-8059-4	159 000 772	Four external dry-contact relays
3-8059-4AC	159 000 773	Four external dry-contact relays with power supply
Additional Outputs, optional; choose zero or one		
3-8900.405-1	159 000 883	Two passive 4 to 20 mA outputs
3-8900.405-2	159 000 884	Two active 4 to 20 mA outputs

Accessories

Mfr. Part No.	Code	Description
3-8050-1	159 000 753	Universal Mount Junction Box
3-8050-2	159 000 754	Universal Mount Junction Box w/EasyCal (for use with 2750)
3-8050.392	159 000 640	Panel adapter, 1/2 DIN to 1/4 DIN
3-8050.395	159 000 186	Splashproof rear cover
3-8050.396	159 000 617	RC Filter kit (for relay use, 2 pieces)
3-0000.596-1	159 000 892	¼ DIN wall mount bracket, 6.5 in. (use if no rear cover is installed)
3-0000.596-2	159 000 893	¼ DIN wall mount bracket, 9 in. (use if rear cover is installed)
3-5000.399	198 840 224	Panel adapter, 5 in. x 5 in. to ¼ DIN
3-5000.598	198 840 225	Shelf/Pipe mount bracket
3-9000.392	159 000 368	Liquid tight connector kit, NPT (3 pieces)
3-9000.392-1	159 000 839	Liquid tight connector kit, NPT (1 piece)
3-9000.392-2	159 000 841	Liquid tight connector kit, PG13.5 (1 piece)

Spare Parts

Mfr. Part No.	Code	Description
3-8900.614	159 000 902	14-terminal plug (for I/O Module)
3-8900.604	159 000 903	4-terminal plug (for Power Module)
3-8900.606	159 000 937	6-terminal plug (for Dry-contact Relays)
3-8900.602	159 000 904	2-terminal plug, 2 ea. (for SSR & Outputs 3 & 4)
3-8900.391	159 000 918	Rear Panel w/ Captive Screws
3-8900.561	159 000 919	Front Face Panel Gasket



Georg Fischer Signet LLC, 3401 Aero Jet Avenue, El Monte, CA 91731-2882 U.S.A. • Tel. (626) 571-2770 • Fax (626) 573-2057
For Worldwide Sales and Service, visit our website: www.gfsignet.com • Or call (in the U.S.): (800) 854-4090
For the most up-to-date information, please refer to our website at www.gfsignet.com