



CustomControlSensors

Non-Hazardous Areas Adjustable Pressure Switch

604P* - Piston Sensor



DESCRIPTION

- Highly reliable devices utilizing the CCS Dual-Snap® Belleville disc spring principle pioneered by CCS' engineers.
 - Engineering based on aerospace technology.
 - Rigid, midsize and internally adjustable for convenient field set point adjustment.
 - Repeatable and stable set points.
 - Vibration and shock resistant.
 - High cycle life.
 - High over-pressure capability. (System and Proof)
- Various options for wetted materials and electrical ratings to meet a wide range of application requirements and media compatibility.
 - Well suited for high impulse hydraulic applications.

SHIPPING WEIGHT: APPROXIMATELY 35 OUNCES (992 GRAMS)

SERIES:

604P*

ADJUSTABLE SET POINT RANGE:

10 to 5000 PSIG
 0.69 to 345 bar
 68.9 to 34474 kPa

OPERATING TEMPERATURE:

Temperature limits change with O-ring selection.

-40° to 186°F
 -40° to 86°C

STANDARD FEATURES:

- CE Mark
- CRN
- CCC
- NACE MR0175 / ISO 15156
- NEMA: 4, 13 / IP65
- Weatherproof
- Internal Case Ground
- U.L. Listed (File No. E72038)

INSTALLATION DRAWING

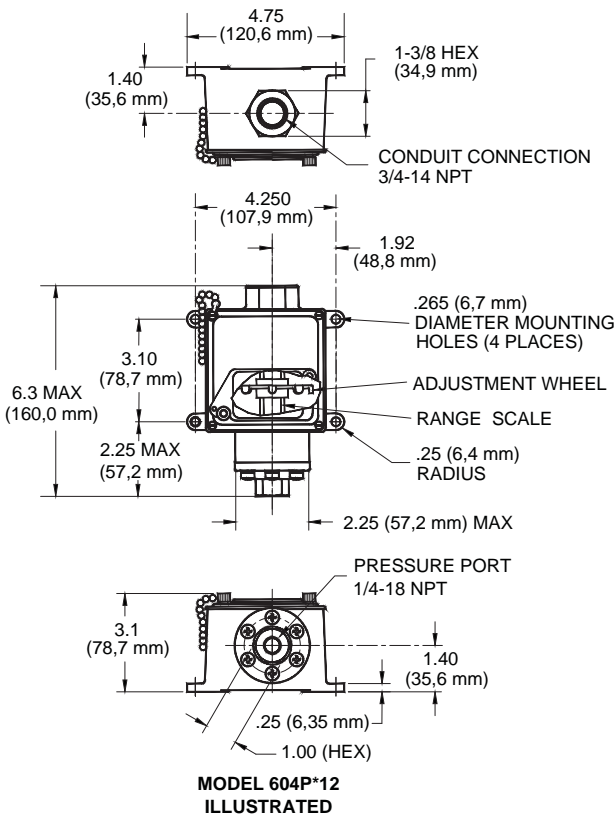

DESIGN PRINCIPLES

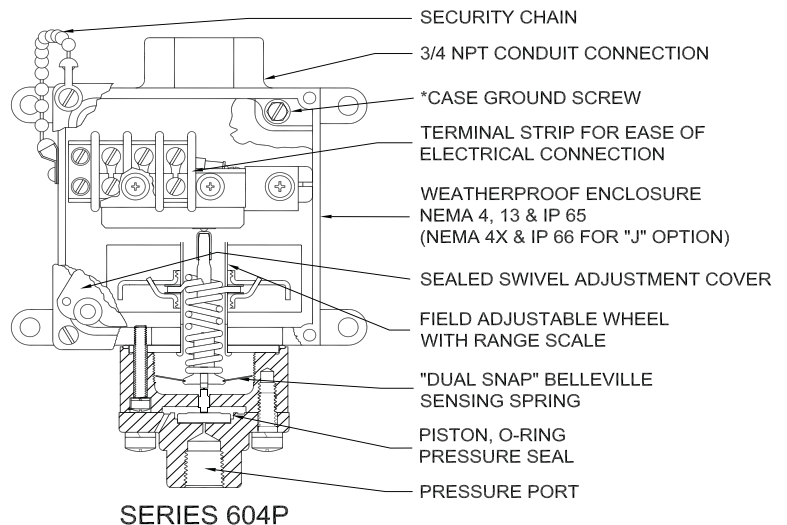

FIELD SETTING: Open access cover. Adjust wheel as illustrated. Clockwise to increase settings. Counterclockwise to decrease settings.

NOTE: DO NOT USE ELECTRICAL HEX FOR TORQUING.





CustomControlSensors

Non-Hazardous Areas Adjustable Pressure Switch

604P* - Piston Sensor

OPERATING AND ORDERING DATA

SERIES 604P*	WETTED PARTS: 1/4"-18 NPT ALUMINUM PRESSURE PORT, 400 STAINLESS STEEL PISTON, BUNA N O-RING/TEFLON				
	ADJUSTABLE SET POINT RANGE		APPROXIMATE DEAD BAND PSI (BAR)	SYSTEM PRESSURE PSIG (BAR)	PROOF PRESSURE PSIG (BAR)
	INCREASING PRESSURE PSIG (BAR)	DECREASING PRESSURE PSIG (BAR)			
604P*12	20-200 (1.4-13.8)	10-188 (0.68-12.9)	10-12 (0.68-0.83)	2000 (138)	3000 (207)
604P*15	170-1400 (11.7-96.5)	90-1230 (6.2-84.8)	80-170 (5.5-11.7)	3000 (207)	5000 (345)
604P*21	300-3000 (20.7-207)	180-2780 (12.4-192)	120-220 (8.3-15.2)	5000 (345)	7500 (517)
604P*31	2500-5000 (172-345)	2220-4520 (153-312)	280-480 (19.3-33.1)	7500 (517)	10,000 (690)

HOW TO ORDER

Follow these steps to build your part number:

1. Specify the series based on your required set point, range, dead band, system pressure and proof pressure.
2. Add desired options model code letter.
3. Add the applicable standard suffix number.

(Ex: 604PA31-7008)

PRESSURE CONVERSION

1 BAR = 14.5 PSI
1 kPa = 0.145 PSI

OPTIONAL STANDARD MODIFIED SUFFIXES

- 7008: Gold Contacts
- 7010: MS33649-4 Port
- 7023: Manual Reset after Increasing

OPTIONS MODEL CODES

- A: Viton® O-Ring
- F: Ethylene Propylene O-Ring
- J: CSA Approved (File No. LR22665) (SPDT ONLY)
- M: DPDT Electrical
- X: Double Break Switching Element

CERTIFICATIONS AND APPROVALS

Consult CCS website for complete certification and approval listing.

ELECTRICAL CHARACTERISTICS

RATING OF SWITCH ELEMENT

VOLTS	AMPERES		
	SPDT	DPDT "M"	Dbl Brk "X"
	Res.	Res.	Res.
125 AC - 50/60 Hz	15	5	15
250 AC - 50/60 Hz	15	5	15
480 AC - 50/60 Hz	15	-	15
28 DC	6	5	-
125 DC	.5	.5	1
250 DC	.2	-	.5
*125 AC - 50/60 Hz	1 max	1 max	-
*30 DC	1 max	1 max	-

*Gold Contacts -7008 Suffix

SCHEMATIC AND WIRING CODE

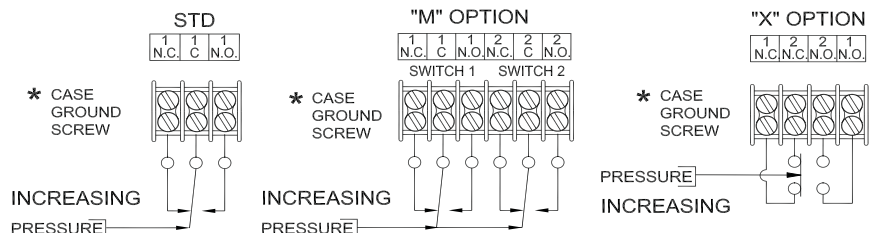

Note: Additional modified standard suffixes are available, consult CCS sales department or CCS Representative.