

# Operating Instructions for Flow Restrictors

**Model: REG**



## 1. Contents

---

1. Contents.....	2
2. Note .....	3
3. Instrument Inspection.....	3
4. Regulation Use.....	3
5. Operating Principle.....	4
6. Mechanical Connection.....	4
7. Technical Information.....	5
8. Differential Pressure Curve.....	5
9. Dimensions and Order Codes.....	6

### Herstellung und Vertrieb durch:

Kobold Messring GmbH  
Nordring 22-24  
D-65719 Hofheim  
Tel.: +49 (0)6192-2990  
Fax: +49(0)6192-23398  
E-Mail: [info.de@kobold.com](mailto:info.de@kobold.com)  
Internet: [www.kobold.com](http://www.kobold.com)

## **2. Note**

---

Please read these operating instructions before unpacking and putting the unit into operation. Follow the instructions precisely as described herein.

The devices are only to be used, maintained and serviced by persons familiar with these operating instructions and in accordance with local regulations applying to Health & Safety and prevention of accidents.

When used in machines, the measuring unit should be used only when the machines fulfil the EWG-machine guidelines.

### **as per PED 97/23/EG**

In acc. with Article 3 Paragraph (3), "Sound Engineering Practice", of the PED 97/23/EC no CE mark.

Diagram 8, Pipe, Group 1 dangerous fluids

## **3. Instrument Inspection**

---

All instruments are inspected before shipping and sent out in perfect condition.

Should damage to a device be visible, we recommend a thorough inspection of the delivery packaging. In case of damage, please inform your parcel service / forwarding agent immediately, since they are responsible for damages during transit.

### **Scope of delivery:**

The standard delivery includes:

- Flow Restrictors model: REG
- Operating Instructions

## **4. Regulation Use**

---

Any use of the Flow Restrictor, model: REG, which exceeds the manufacturers specification may invalidate its warranty. Therefore, any resulting damage is not the responsibility of the manufacturer. The user assumes all risk for such usage.

## 5. Operating Principle

---

KOBOLD model REG flow restrictors serve to keep constant quantities of liquids in pipework systems. The REG rate regulators are ideally suited for the simple restriction of a preset value of throughputs of water or of liquids similar to water. The flow restrictors ensure an equilibrium, particularly in systems with many consumers and resulting pressure fluctuations caused by random flow conditions. In other words, the desired throughput is not exceeded.

Constant flow is achieved by two stainless steel spring plates that are crosswise mounted and riveted together. The gap between the spring-loaded stainless steel plate and the seal-surface is continuously varied as the differential pressure changes. As the differential pressure decreases, the gap widens, and it closes as the pressure increases, thus maintaining a constant flow volume through the device.

## 6. Mechanical Connection

---

### Before installation:

- Remove all transport securing devices and make sure that there are no more packaging parts left in the device.
- Make sure that the permitted maximum operating pressures and temperatures for the device are not exceeded (see 7 Technical Information)
- Install the flow limiter into the piping without mechanical stress.
- Protect the measuring pipe against external damage.
- Avoid pressure surges in the measuring pipe e.g. by blocking the flow quickly.
- If possible, after mechanical installation, make sure that the connection between screw connection and pipe is tight and does not leak.

Maximum tightening torques for process connection:

G ½	30 Nm
G ¾	30 Nm
G1	38 Nm



---

**Warning! The differential pressure must not exceed 10 bar.**

---

## 7. Technical Information

Connections:	female thread G 1/2, G 3/4 female/male thread G 1/2-G 3/4 male thread G 3/4
	female thread 3/4 NPT female/male thread 3/4 NPT
	multiple element male thread G 1 1/2, G 2, G 2 1/4, G 2 1/2 Flange DN 20/25/32/40/50
Service temperature:	-10...+300 °C
Operating pressure:	max. 200 bar
Differential pressure:	min. 2.0 bar
Differential pressure:	max. 10 bar
Materials	
(see drawing for details):	
Brass-version	brass and stainless steel
Stainless steel-version	all stainless steel
Viscosity:	max. 30 mm <sup>2</sup> /s

## 8. Differential Pressure Curve

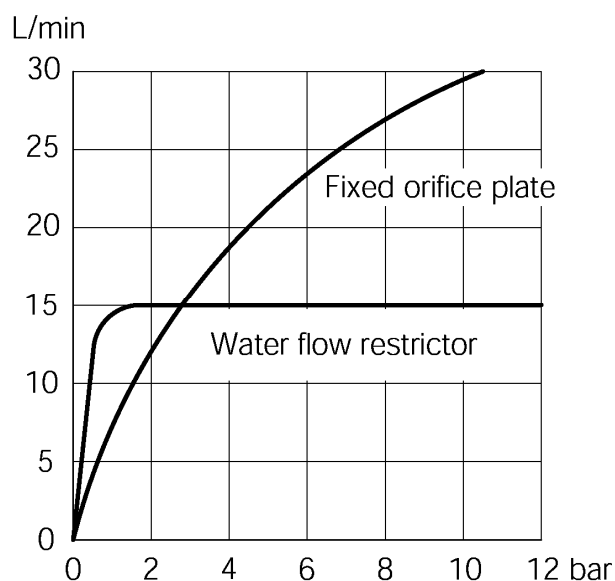

## 9. Dimensions and Order Codes

REG-1x/REG-2x/REG-5x

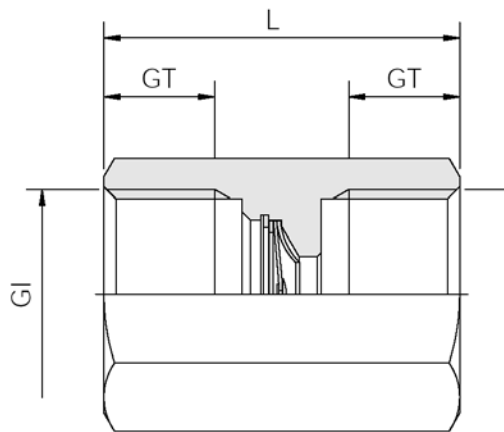

REG-3x/REG-4x/REG-6x

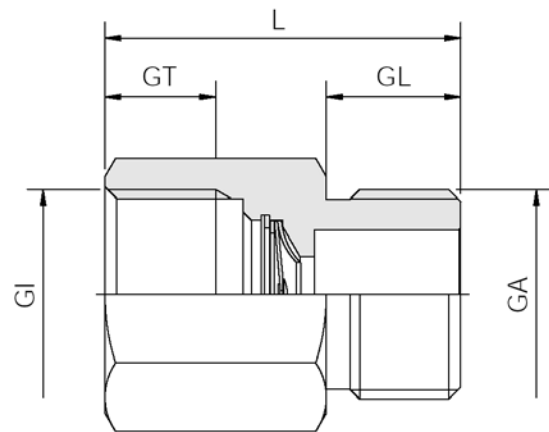

### REG-0x with design and materials

1 Valve body	brass Ms 58 or st. steel 1.4301
2 Pan	st. steel 1.4301
3 Spring star	st. steel 1.4310
4 Ring	st. steel 1.4301
5 Circlip	st. steel 1.4122

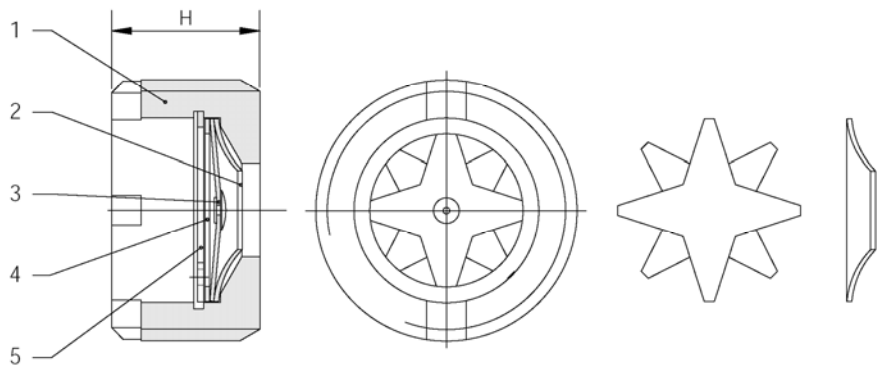

## Dimensions and Order Details G screw thread (example: REG-0101)

Dimensions		Male thread G 3/4		Female/female thread* G 1/2		Female/female thread G 3/4		Female/male thread G 1/2		Female/male thread G 3/4	
L [mm]	-	-		36 (42)		45 (50)		36 (42)		45 (50)	
GT [mm]	-	-		12 (14)		14 (16)		13 (14)		14 (16)	
GL [mm]	-	-		-		-		12 (14)		17 (16)	
GI	-	-		G 1/2		G 3/4		G 1/2		G 3/4	
GA	-	-		-		-		G 1/2		G 3/4	
AF [mm]	-	-		24 (27)		30 (36)		24 (27)		30 (36)	
H [mm]	15	-		-		-		-		-	
Through- put L/min	Tolerance L/min	Brass	Stainless steel	Brass	Stainless steel	Brass	Stainless steel	Brass	Stainless steel	Brass	Stainless steel
0,5	± 0.2	REG-0100	REG-0200	REG-1100	REG-1200	REG-2100	REG-2200	REG-3100	REG-3200	REG-4100	REG-4200
1	± 0.2	REG-0101	REG-0201	REG-1101	REG-1201	REG-2101	REG-2201	REG-3101	REG-3201	REG-4101	REG-4201
2	± 0.2	REG-0102	REG-0202	REG-1102	REG-1202	REG-2102	REG-2202	REG-3102	REG-3202	REG-4102	REG-4202
3	± 0.4	REG-0103	REG-0203	REG-1103	REG-1203	REG-2103	REG-2203	REG-3103	REG-3203	REG-4103	REG-4203
4	± 0.4	REG-0104	REG-0204	REG-1104	REG-1204	REG-2104	REG-2204	REG-3104	REG-3204	REG-4104	REG-4204
5	± 0.5	REG-0105	REG-0205	REG-1105	REG-1205	REG-2105	REG-2205	REG-3105	REG-3205	REG-4105	REG-4205
6	± 0.5	REG-0106	REG-0206	REG-1106	REG-1206	REG-2106	REG-2206	REG-3106	REG-3206	REG-4106	REG-4206
8	± 0.5	REG-0108	REG-0208	REG-1108	REG-1208	REG-2108	REG-2208	REG-3108	REG-3208	REG-4108	REG-4208
9	± 0.7	REG-0109	REG-0209	REG-1109	REG-1209	REG-2109	REG-2209	REG-3109	REG-3209	REG-4109	REG-4209
10	± 0.7	REG-0110	REG-0210	REG-1110	REG-1210	REG-2110	REG-2210	REG-3110	REG-3210	REG-4110	REG-4210
11	± 0.7	REG-0111	REG-0211	REG-1111	REG-1211	REG-2111	REG-2211	REG-3111	REG-3211	REG-4111	REG-4211
12	± 0.7	REG-0112	REG-0212	REG-1112	REG-1212	REG-2112	REG-2212	REG-3112	REG-3212	REG-4112	REG-4212
16	± 1.2	REG-0116	REG-0216	REG-1116	REG-1216	REG-2116	REG-2216	REG-3116	REG-3216	REG-4116	REG-4216
20	± 1.2	REG-0120	REG-0220	REG-1120	REG-1220	REG-2120	REG-2220	REG-3120	REG-3220	REG-4120	REG-4220
25	± 1.5	REG-0125	REG-0225	REG-1125	REG-1225	REG-2125	REG-2225	REG-3125	REG-3225	REG-4125	REG-4225
30	± 1.5	REG-0130	REG-0230	REG-1130	REG-1230	REG-2130	REG-2230	REG-3130	REG-3230	REG-4130	REG-4230
40	± 2	REG-0140	REG-0240	REG-1140	REG-1240	REG-2140	REG-2240	REG-3140	REG-3240	REG-4240	REG-4240

\*Values in brackets for versions with extended thread (please add D to the order number)

## Dimensions and Order Details NPT screw thread (example: REG-5101)

Dimensions		Female/female thread ¾ NPT		Female/male thread ¾ NPT	
L [mm]		45		45	
GT [mm]		14		14	
GL [mm]		-		17	
GI		¾ NPT		¾ NPT	
GA		-		¾ NPT	
AF [mm]		30		30	
H [mm]		-		-	
Throughput L/min	Tolerance L/min	Brass	Stainless steel	Brass	Stainless steel
0,5	± 0,2	REG-5100	REG-5200	REG-6100	REG-6200
1	± 0,2	REG-5101	REG-5201	REG-6101	REG-6201
2	± 0,2	REG-5102	REG-5202	REG-6102	REG-6202
3	± 0,4	REG-5103	REG-5203	REG-6103	REG-6203
4	± 0,4	REG-5104	REG-5204	REG-6104	REG-6204
5	± 0,5	REG-5105	REG-5205	REG-6105	REG-6205
6	± 0,5	REG-5106	REG-5206	REG-6106	REG-6206
8	± 0,5	REG-5108	REG-5208	REG-6108	REG-6208
9	± 0,7	REG-5109	REG-5209	REG-6109	REG-6209
10	± 0,7	REG-5110	REG-5210	REG-6110	REG-6210
11	± 0,7	REG-5111	REG-5211	REG-6111	REG-6211
12	± 0,7	REG-5112	REG-5212	REG-6112	REG-6212
16	± 1,2	REG-5116	REG-5216	REG-6116	REG-6216
20	± 1,2	REG-5120	REG-5220	REG-6120	REG-6220
25	± 1,5	REG-5125	REG-5225	REG-6125	REG-6225
30	± 1,5	REG-5130	REG-5230	REG-6130	REG-6230
40	± 2	REG-5140	REG-5240	REG-6140	REG-6240



## Order Details multiple element (example: REG-92 R402 080)

Design	Size	Throughput* in L/min
REG-92... Multiple element made of stainless steel 1.4301	..R402..=G 1 1.2; 2-fold	1.0...080
	..R403..=G 1 1.2; 3-fold	1.5...120
	..R503..= G 2; 3-fold	1.5...120
	..R504..= G 2; 4-fold	2.0...160
	..R585..=G 2 1.4; 5-fold	2.5...200
	..R656..=G 2 1.2; 6-fold	3.0...240
	..R657..=G 2 1.2; 7-fold	3.5...280

\*The throughput is calculated by adding the regulating inserts (see also single elements).

**Example: The throughput 55 L/min is obtained with one restrictor with two regulating inserts (30 plus 25 L/min).**

REG-92R402

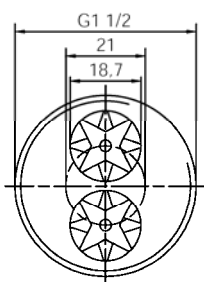

REG-92R403

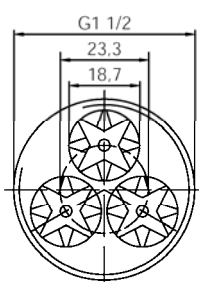

REG-92R503

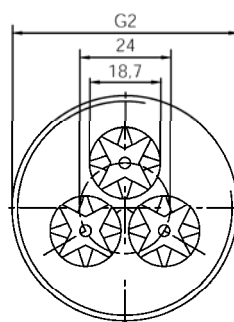

REG-92R504

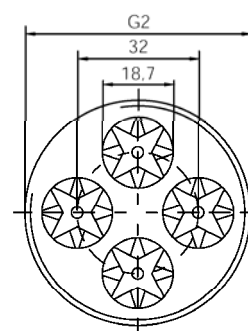

REG-92R585

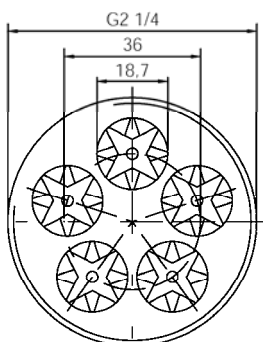

REG-92R656

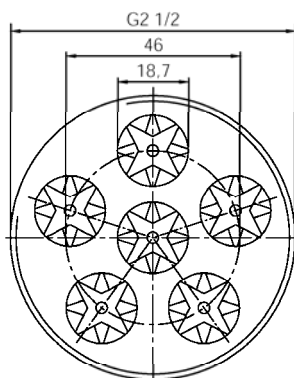

REG-92R657

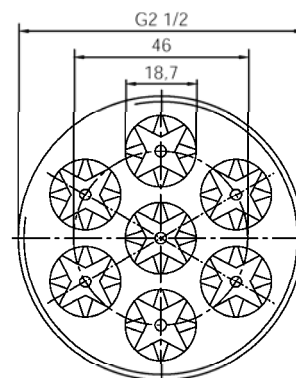

**Thickness: 15 mm**

## Order Details multiple element – flange version (example: REG-82 F20 2 080)

Design	Flange	Number of regulating inserts	Throughput* in L/min
<b>REG-82...</b> Multiple element with flange EN 1092-1, PN 16-40 stainless steel 1.4301/1.4571	..F20..= DN 20	..2.. = 2 fold	040... <b>080</b>
		..3.. = 3 fold	040... <b>120</b>
	..F25..= DN 25	..2.. = 2 fold	040... <b>080</b>
		..3.. = 3 fold	040... <b>120</b>
		..4.. = 4 fold	040... <b>160</b>
		..5.. = 5 fold	040... <b>200</b>
	..F32..= DN 32 ..F40..= DN 40 ..F50..= DN 50	..2.. = 2 fold	040... <b>080</b>
		..3.. = 3 fold	040... <b>120</b>
		..4.. = 4 fold	040... <b>160</b>
		..5.. = 5 fold	040... <b>200</b>
		..6.. = 6 fold	040... <b>240</b>
		..7.. = 7 fold	040... <b>280</b>

\*The throughput is calculated by adding the regulating inserts (see also single elements).

**Example: The throughput 55 L/min is obtained with one restrictor with two regulating inserts (30 plus 25 L/min).**

### REG-82F325

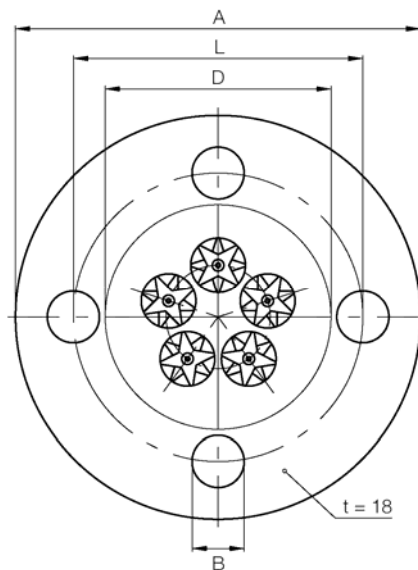

### REG-82 Fxx-Flange-dimensions for PN 16-40

DN	Außen-Ø [A]	Lochkreis-Ø [L]	Bohrungs- Ø [B]	Schrauben	Dichtflächen- Ø* [D]
20	105	75	14	4 x M 12	58
25	115	85	14	4 x M 12	68
32	140	100	18	4 x M 16	78
40	150	110	18	4 x M 16	88
50	165	125	18	4 x M 16	102