

DRB/DPE TURBINE WHEEL FLOWMETERS



Flow
Pressure
Level
Temperature
measurement
monitoring
control



- Flow ranges 1.5-8 GPM to 15-200 GPM
- Bronze or stainless steel bodies
- Frequency or 4-20 mA output
- Electronic displays and controllers
- Max. Pressure 580 PSIG

S4

Authorized Distributor:
ControlSystemsUsa.com
Houston, TX USA
832-615-3588
sales@ControlSystemsUsa.com

Model:
DRB/DPE



Features

- Flow range 1.5-8 GPM to 15-200 GPM
- Bronze or stainless steel bodies
- Frequency or 4-20 mA output
- Electronic displays and controllers
- Max. pressure 580 PSIG

The DRB and DPE series turbine wheel flowmeters are an economical yet very reliable solution for measuring liquid flows in pipes up to 3 inches in diameter. The unique "insertion" impeller design protrudes minimally into the flow stream which minimizes head loss and allows measurement of dirty liquids, and liquids with high solid content, without risk of failure. The DRB and DPE series feature a PVDF impeller supported on a sapphire bearing system which provides an exceptionally long life and excellent chemical resistance properties. The DRB and DPE series are available with either bronze or stainless steel threaded bodies. A Hall effect sensor detects the passing of permanent magnets imbedded in the impeller blades. The output of the Hall sensor is converted to a linear pulse or 4-20 mA signal. Optionally, a variety of displays and controllers is available to provide flow rate indication, analog outputs and programmable setpoint switches. The DRB and DPE series' combination of simple, reliable design and variety of body materials and electronics options makes them a sure solution for the toughest flow metering applications.

Specifications

Accuracy:

- DRB Series: $\pm 3\%$ of full scale
- DPE Series: $\pm 2.5\%$ of full scale

Maximum Pressure

- DRB Series: 250 PSIG
- DPE Series: 580 PSIG

Operating Temperature:

-10 to 176°F

Materials of Construction

- Body:** Bronze or 316 stainless steel
- Impeller:** PVDF
- Axle:** 316 stainless steel
- Bearings:** Sapphire
- O-rings:** NBR for bronze bodies, FKM for SS bodies

Piping Straight Run Requirement:

- 20 X pipe diameter upstream
- 10 X pipe diameter downstream



Electrical Specifications

Frequency Output

- Output Type:** PNP open collector, 25 mA max.

- Power Requirement:** 14-28 VDC

- Electrical Protection:** NEMA 4X

- Electrical Connection:** Micro-DC plug, 4-pin male

4-20 mA Output

- Output Type:** 4-20 mA, 2-wire or 3-wire depending on model

- Max. Loop Load:** 500 ohms
- Power Requirement:** 24 VDC $\pm 20\%$

- Electrical Connection:** Micro-DC plug, 4-pin male or DIN 43650 (Hirschmann) plug

- Electrical Protection:** NEMA 4X

Compact Electronics

- Output Type:** 4-20 mA, 3-wire & PNP switch or 2 PNP switches

- Switch Rating:** 300 mA Max. short circuit protected flow switch or frequency transmitter

- Power Requirement:** 24 VDC $\pm 20\%$
- Display Type:** 3 digit LED

User Programmable

- Functions:** Transmitter span, switch setpoint, lockout code

- Housing:** 304 SS, NEMA 4X
- Electrical Connection:** Micro-DC plug, 5-pin male

Electronic Display/Controller

- Output Type:** 4-20 mA, 4-wire and 2 adjustable setpoint relays

- Relay Rating:** SPDT 5 amps @ 230 VAC
- Input Power:** 115 VAC
- Display Type:** 3-1/2 digit LED and 270° bargraph

- Enclosure:** Epoxy coated aluminum and polycarbonate, NEMA 4X

Ordering Codes for DRB Series

Range GPM	Materials		Fitting	Output/Electronics
	Bronze	Stainless Steel		
1.5-8	DRB-1150	DRB-1250	N4=1/2" NPT	F300=Frequency output, Micro-DC plug L342 = 4-20 mA, 2-wire, Micro-DC plug L343=4-20 mA, 3-wire, Micro-DC plug L442=4-20 mA, DIN 43650 plug C34P=Compact electronic, 4-20 mA + 1 PNP switch C30R=Compact electronic, 2 PNP switches K442=Display & Controller Z340=Analog Indicator + 4-20mA, 3-wire
3-13	DRB-1155	DRB-1255	N5=3/4" NPT	
5.5-20	DRB-1160	DRB-1260	N6=1" NPT	
6.6-65	DRB-1165	DRB-1265	N8=1-1/2" NPT	
8-90	DRB-1170	DRB-1270	N9= 2" NPT	
15-200	DRB-1175	DRB-1275	NB=3" NPT	
Accessories				
Part Number 807.037=Mating 4-pin Micro-DC plug with 6 ft. cable for output F300, L342, L343 & Z340 Part Number 807.007=Mating 5-pin Micro-DC plug with 6 ft. cable for output C34P & C30R				

Example DRB-1150N4F300

Ordering Codes for DPE Series

Range GPM	Materials		Fitting	Output/Electronics
	Bronze	Stainless Steel		
1.5-8	DPE-1150	DPE-1250	N4=1/2" NPT	F300=Frequency output, Micro-DC plug L342=4-20 mA, 2-wire, Micro-DC plug L343=4-20 mA, 3-wire, Micro-DC plug L442=4-20 mA, DIN 43650 plug C34P=Compact electronic, 4-20 mA + 1 PNP switch C30R=Compact electronic, 2 PNP switches K442=Display & Controller Z340=Analog Indicator + 4-20mA, 3-wire
3-13	DPE-1155	DPE-1255	N5=3/4" NPT	
5.5-20	DPE-1160	DPE-1260	N6=1" NPT	
6.6-65	DPE-1165	DPE-1265	N8=1-1/2" NPT	
8-90	DPE-1170	DPE-1270	N9= 2" NPT	
15-200	DPE-1175	DPE-1275	NB=3" NPT	
Accessories				
Part Number 807.037=Mating 4-pin Micro-DC plug with 6 ft. cable for output F300, L342, L343 & Z340 Part Number 807.007=Mating 5-pin Micro-DC plug with 6 ft. cable for output C34P & C30R				

S4

Example DPE-1150N4F300



DRB/DPE with Analog Indicator



DRB/DPE with compact electronics



DRB/DPE with display /controller

Dimensions

DRB/DPE transmitter only (frequency or 4-20 mA)

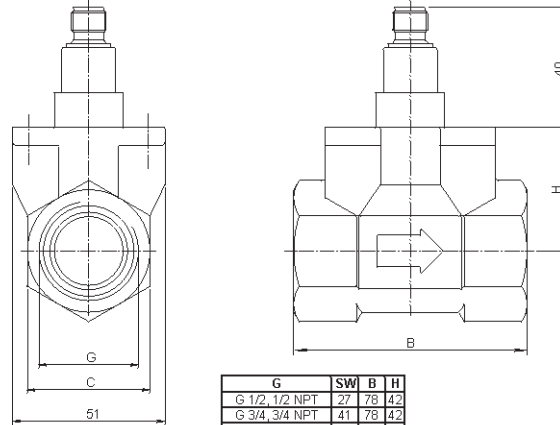

G	SW	B	H
G 1/2, 1/2 NPT	27	78	42
G 3/4, 3/4 NPT	41	78	42
G 1, 1 NPT	41	78	42
G 1 1/2, 1 1/2 NPT	55	78	57
G 2, 2 NPT	70	81	55
G 3, 3 NPT	100	106	72

DRB/DPE with compact electronics

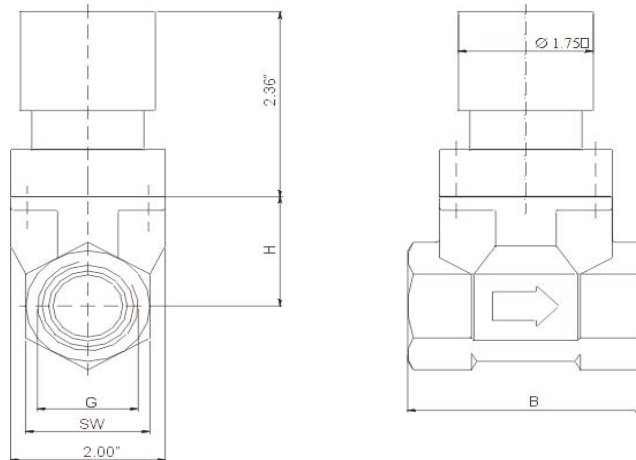

G	SW	B	H
G 1/2, 1/2 NPT	1.06"	3.07"	1.65"
G 3/4, 3/4 NPT	1.61"	3.07"	1.65"
G 1, 1 NPT	1.61"	3.07"	1.65"
G 1 1/2, 1 1/2 NPT	2.16"	3.07"	2.24"
G 2, 2 NPT	2.75"	3.18"	2.16"
G 3, 3 NPT	3.93"	4.17"	2.83"

DRB/DPE with display & controller

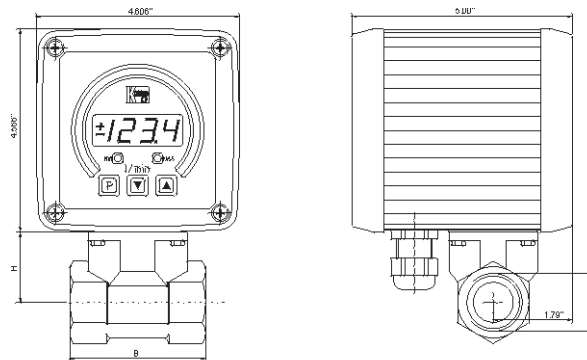

G	SW	B	H
G 1/2, 1/2 NPT	1.06"	3.07"	1.65"
G 3/4, 3/4 NPT	1.61"	3.07"	1.65"
G 1, 1 NPT	1.61"	3.07"	1.65"
G 1 1/2, 1 1/2 NPT	2.16"	3.07"	2.24"
G 2, 2 NPT	2.75"	3.18"	2.16"
G 3, 3 NPT	3.93"	4.17"	2.83"