



Full Metal Variable Area Flow Meter and Counter

for Liquids and Gases



measuring
•
monitoring
•
analysing

BGN

Special versions up to 600 bar
•
Nominal diameter up to DN 150



Fieldbus
FOUNDATION



- Measuring range:
0.5-5.0... 13000- 130000 l/h water
0.015-0.15... 240-2400 m³/h air
(20 °C, 1.013 bar)
- Accuracy class: 1.6
- p_{max} : PN 40; t_{max} : -40... +350 °C
- Connection: flange DN 15... DN150
- Material: stainless steel 1.4404/1.4571, Hastelloy C, PTFE
- Option: contacts, analogue output with HART®, Profibus® PA or Fieldbus® Foundation™, counter



S2

KOBOLD companies worldwide:

ARGENTINA, AUSTRALIA, AUSTRIA, BELGIUM, BULGARIA, CANADA, CHILE, CHINA, COLOMBIA, CZECHIA, EGYPT, FRANCE, GERMANY, GREAT BRITAIN, HUNGARY, INDIA, INDONESIA, ITALY, MALAYSIA, MEXICO, NETHERLANDS, PERU, POLAND, REPUBLIC OF KOREA, ROMANIA, SINGAPORE, SPAIN, SWITZERLAND, TAIWAN, THAILAND, TUNISIA, TURKEY, USA, VIETNAM

KOBOLD Messring GmbH
Nordring 22-24
D-65719 Hofheim/Ts.
Head Office:
+49(0)6192 299-0
+49(0)6192 23398
info.de@kobold.com
www.kobold.com



Functions

The fluid flows from bottom to top through the meter tube of the flow meter. The float is lifted until an annular gap between the meter ring and the cone-shaped float is produced which corresponds to the flow. The forces acting on the float are in equilibrium. The forces that are mainly acting on the float comprise buoyancy according to the principle of Archimedes, the flow force of the medium and the weight force. Each position of the float corresponds to a flow value measured during calibration, which is transferred to a scale. The BGN variable area flow meter consists of a meter tube with connections, a meter ring, and a conical float. By means of a magnet, the position of the float is transferred to an encapsulated follow magnet, which has been fitted to a pointer axle. The position of a second annular follow magnet fitted on the pointer axle is transferred to the scale by means of the pointer.

Application

The KOBOLD-BGN meter is suitable for flow measurement of liquid or gaseous products in pipes. It shows the current flow rate in volume or mass per unit in time.

Applications

Flow measurement, dosing, monitoring, adjusting and control of liquid and gaseous products. The meter's design makes it ideal for processes under difficult and rough operating conditions. The devices are available with additional electrical equipment for process monitoring and control.

- A large spectrum of wetted materials
- Magneto-resistive signal transmission
- Gas- or liquid damping (option)
- Special design for high-pressure and high-temperature applications
- Excellent heat tracing technology (option)
- Double eddy current damping (special version)
- Self draining (special version)
- Backflow stop (special version)
- Flow Controller (special version)

Technical Details

Sensor

Materials: 1.4404 (316 L) / 1.4571 (316 Ti), Hastelloy C-22, PTFE other materials on request

Process connection: Flanges acc. EN 1092, ASME B16.5, DIN 2512, JIS, NPT, screw pipe connection, special connections on request

Nominal pressure: PN 40, ASME CI150 / 300 (standard) (BGN-S/H) PN 16, ASME CI150 (standard) (BGN-P) higher pressure rates optional

(max. 600 bar)

Process temperature: -40 °C ... +200 °C (BGN-S/H without electr. output) -40 °C ... +150 °C (BGN-S/H with electr. output) -40 °C ... +350 °C (BGN-S/H with option V/ H / W) -40 °C ... +125 °C (BGN-P)

Ambient temperature: -40 °C ... +80 °C

Accuracy

Liquid: ± 1.6 % of full scale (BGN-S/H) ± 2.0 % of full scale (BGN-P)

Gas: ± 1.8 % of full scale (BGN-S/H) ± 2.2 % of full scale (BGN-P)

Additional inaccuracy through transmitter (ES): ± 0.2 %

Repeatability: ± 0.5 % of full scale

Protection: IP 65 (aluminium housing) IP 67 (stainless steel housing)

Certification

Explosion protection: BVS 03 ATEX H/B 112

CE-Marking: Pressure Equipment Directive 97/23/Eg



Technical Details (continued)

Display

Material:	aluminium (stove-enameled) stainless steel (as option)
Electrical outputs:	Inductive switch, SJ 3,5-N NAMUR (standard)* Inductive switch, SJ 3,5-SN NAMUR (safety design)* on request Microswitch* others on request
Ambient temperature:	-40 °C ... +80 °C (without limit switch) -40 °C ... +65 °C (with limit switch)

* Using the segments of the slot-type initiators or the eccentric discs of the microswitches, any switching point between 10 % and 90 % of the flow rate can be set.

Additional options and special versions:

- Other materials
- Other flange versions and sizes
- Certifications
- Display with pressure compensations against condensate build up
- Microswitch
- Inductive switches with safety design
- Double eddy current damping
- Self draining
- Backflow stop
- Flow controller
- specialy low pressure loss

Transmitter

- ES with HART®-protocol
- ES with HART®-protocol and 2 NAMUR-switches*
- ES with HART®-protocol and 1 NAMUR-switch* / 1 pulse output
- ES with Profibus® PA
- ES with HART®-protocol and counter module
- ES with Fieldbus® Foundation™

* Contact can be configured using HART®

Power supply:	14 - 30 V _{DC}
Output:	passive, galvanically isolated
Current:	4-20 mA
Binary 1 and 2:	U _i = 30 V, I _i = 20 mA, P _i = 100 mW
Input Binary:	Counter reset (only for ES with counter module)
Ambient temperature:	-40 °C... +70 °C

Certification

Explosion protection:	DMT 00 ATEX E 075
Type of protection:	 II 2G EEx ia IIC T6
CE-Marking:	Explosion Protection Directive 94/9/EG



Full Metal Variable Area Flow Meter and Counter Model BGN

Order details for liquids (Example: BGN-S 10305B A 0000 S 1 0)

Model	Measuring range [l/h]	Measuring range air at 20°C, 1013 mbar [Nm³/h]	Connection size	Pressure stage (DIN-Flansch)	Max. pressure loss [mbar]	Code ²⁾ flange DIN EN1092-1 Form B1	Code ²⁾ flange ASME Class 150 RF
BGN-S = stainless steel measuring tube	0.5-5 (0.7-7) ¹⁾⁴⁾	0.015 - 0.15	DN 15, (¾")	PN 40	40	10305B A	10202R A
	1-10 (1.2-12) ¹⁾⁴⁾	0.03 - 0.3	DN 15, (¾")	PN 40	44	10305B B	10202R B
	1.6-16 (2-20) ¹⁾⁴⁾	0.145 - 0.48	DN 15, (¾")	PN 40	40	10305B C	10202R C
	2.5-25 ³⁾⁴⁾	0.075 - 0.75	DN 15, (¾")	PN 40	40	10305B D	10202R D
	4-40 ³⁾⁴⁾	0.13 - 1.3	DN 15, (¾")	PN 40	40	10305B E	10202R E
	5-50	0.15 - 1.5	DN 15, (¾")	PN 40	40	15305B F	15202R F
	7-70	0.2 - 2.1	DN 15, (¾")	PN 40	40	15305B G	15202R G
	10-100	0.3 - 3.0	DN 15, (¾")	PN 40	60	15305B H	15202R H
	16-160	0.5 - 4.6	DN 15, (¾")	PN 40	60	15305B I	15202R I
	25-250	0.7 - 7.0	DN 15, (¾")	PN 40	60	15305B J	15202R J
	40-400	1.0 - 11	DN 15, (¾")	PN 40	70	15305B K	15202R K
	60-600	1.7 - 17	DN 15, (¾")	PN 40	80	15305B L	15202R L
	0.5-5 (0.7-7) ¹⁾⁴⁾	0.015 - 0.15 ¹⁾⁴⁾	DN 25, 1"	PN 40	40	10309B A	10203R A
	1-10 (1.2-12) ¹⁾⁴⁾	0.03 - 0.3 ¹⁾⁴⁾	DN 25, 1"	PN 40	44	10309B B	10203R B
	1.6-16 (2-20) ¹⁾⁴⁾	0.145 - 0.48 ¹⁾⁴⁾	DN 25, 1"	PN 40	40	10309B C	10203R C
	2.5-25 ³⁾⁴⁾	0.075 - 0.75 ³⁾⁴⁾	DN 25, 1"	PN 40	40	10309B D	10203R D
	4-40 ³⁾⁴⁾	0.13 - 1.3 ³⁾⁴⁾	DN 25, 1"	PN 40	40	10309B E	10203R E
	5-50	0.15 - 1.5	DN 25, 1"	PN 40	40	15309B F	15203R F
	7-70	0.2 - 2.1	DN 25, 1"	PN 40	40	15309B G	15203R G
	10-100	0.3 - 3.0	DN 25, 1"	PN 40	60	15309B H	15203R H
16-160	0.5 - 4.6	DN 25, 1"	PN 40	60	15309B I	15203R I	
25-250	0.7 - 7.0	DN 25, 1"	PN 40	60	15309B J	15203R J	
40-400	1.0 - 11	DN 25, 1"	PN 40	70	15309B K	15203R K	
BGN-P = stainless steel measuring tube, PTFE-casing	60-600	1.7 - 17	DN 25, 1"	PN 40	80	15309B L	15203R L
	100-1000	3 - 30	DN 25, 1"	PN 40	60	25309B M	25203R M
	160-1600	4 - 46	DN 25, 1"	PN 40	70	25309B N	25203R N
	250-2500	7 - 70	DN 25, 1"	PN 40	100	25309B P	25203R P
	400-4000 ³⁾⁸⁾	11 - 110 ³⁾⁸⁾	DN 25, 1"	PN 40	240	25309B Q	25203R Q
BGN-H = Hastelloy measuring tube	250-2500	7 - 70	DN 40, 1 ½"	PN 40	50	40317B P	40205R P
	400-4000	11 - 110	DN 40, 1 ½"	PN 40	120	40317B Q	40205R Q
	600-6000	17 - 170	DN 40, 1 ½"	PN 40	180	40317B R	40205R R
	400-4000	11 - 110	DN 50, 2"	PN 40	80	50321B Q	50206R Q
	600-6000	17 - 170	DN 50, 2"	PN 40	90	50321B R	50206R R
	1000-10000	29 - 290	DN 50, 2"	PN 40	110	50321B S	50206R S
	1600-16000	46 - 460	DN 50, 2"	PN 40	230	50321B T	50206R T
	2500-25000 ³⁾⁹⁾	70 - 700 ³⁾⁹⁾	DN 50, 2"	PN 40	500	50321B U	50206R U
	1600-16000	46 - 460	DN 80, 3"	PN 40	70	80331B T	80208R T
	2500-25000	70 - 700	DN 80, 3"	PN 40	100	80331B U	80208R U
	4000-40000 ³⁾	110 - 1100	DN 80, 3"	PN 40	350	80331B V	80208R V
	4000-40000	110 - 1100	DN 100, 4"	PN 16	120	1H335B V	1H210R V
	6000-60000 ³⁾ (5500-55000) ¹⁾	170 - 1700	DN 100, 4"	PN 16	360	1H335B W	1H210R W
	8000-80000 ³⁾	240 - 2400 ³⁾	DN 100, 4"	PN 16	600	1H335B X	1H210R X
	10000-100000 ³⁾⁷⁾	-	DN 100, 4"	PN 16	on request	1H335B 2	1H210R 2
4000-40000	on request	DN 125, 5"	PN 16	on request	1H340B V	1H211R V	
6000-60000 ³⁾ (5500-55000) ¹⁾	on request	DN 125, 5"	PN 16	on request	1H340B W	1H211R W	
8000-80000 ³⁾	on request	DN 125, 5"	PN 16	on request	1H340B X	1H211R X	
10000-100000 ³⁾⁷⁾	on request	DN 125, 5"	PN 16	on request	1H340B 2	1H211R 2	
10000-100000 ³⁾	on request	DN 150, 6"	PN 16	on request	H5345B 2	H5212R 2	
13000-130000 ³⁾	on request	DN 150, 6"	PN 16	on request	H5345B 4	H5212R 4	



Continuation order details for liquids (Example: BGN-S 10305B A 0000 S 1 0)

Heating ³⁾ / cooling	Damping ³⁾ / spring stop	Draining body	Certificates	Display	Scale	Electrical output
<p>0 = without</p> <p>1 = with heating Ermeto 12 mm</p> <p>2 = with heating DIN-flange DN15/PN 40</p> <p>3 = with heating ANSI-flange ½" Class 150</p>	<p>0 = without</p> <p>R = with flow restrictor for gas measuring⁵⁾</p> <p>F = with liquid damping</p> <p>G = with gas damping</p> <p>A = with spring stop</p> <p>S = with gas damping and spring stop⁶⁾</p>	<p>0 = without</p> <p>L = with self draining body</p>	<p>0 = without certificate</p> <p>1 = Certificate of compliance with the order 2.1</p> <p>2 = Certificate of compliance with the order 2.2</p> <p>B = Inspection certificate with material certificate 3.1</p> <p>C = Inspection certificate with material certificate 3.2</p>	<p>S = aluminium</p> <p>V = aluminium, assembled at distance up to 350 °C</p> <p>E = stainless steel</p> <p>H = stainless steel, assembled at distance up to 350 °C</p> <p>T = aluminium with pressure compensation</p> <p>W = aluminium with pressure compensation, assembled at distance up to 350 °C</p>	<p>Water</p> <p>1 = %-scale</p> <p>2 = measuring range</p> <p>Media</p> <p>4 = %-scale</p> <p>5 = measuring range</p> <p>Please specify media data in plain text (see below)</p>	<p>0 = without</p> <p>1 = 1 inductive limit switch, SIL-1⁹⁾</p> <p>2 = 2 inductive limit switches, SIL-1⁹⁾</p> <p>C = 1 micro switch</p> <p>D = 2 micro switches</p> <p>6 = transmitter ES with HART®, EEx ia, 4-20 mA, SIL-1⁹⁾</p> <p>7 = transmitter ES with HART®, EEx ia, 4-20 mA and 2 NAMUR-switches, SIL-1⁹⁾</p> <p>8 = transmitter ES with HART®, EEx ia, 4-20 mA, 1 NAMUR-switch and 1 pulse output, SIL-1⁹⁾</p> <p>9 = electrical transmitter ES with Profibus® PA, EEx ia</p> <p>I = 4-20 mA with HART® and counter module</p> <p>K = electrical transmitter ES with Fieldbus® Foundation™</p>

Reference conditions: water at 20 °C, 1 mPas

- ¹⁾ Different measuring range for model BGN-P (PTFE-chasing)
- ²⁾ Other flange connections: Form B1, N, D, JIS or Class 300 on request
- ³⁾ Not for model BGN-P (PTFE-casing)
- ⁴⁾ Not for model BGN-H (Hastelloy)
- ⁵⁾ Only up to measuring range: 40 l/h
- ⁶⁾ Only for nominal diameter DN 100
- ⁷⁾ Damping not possible
- ⁸⁾ Not available with heating / cooling
- ⁹⁾ IEC 61508-2:2010 Conformity confirmed by EXIDA

For the right design of the flowmeter we need the following data:
measuring range with unit, measured media, process temperature and pressure, viscosity, operating density (liquids), norm density (gases), mechanical connections

Dimensions [mm]

Display: aluminium

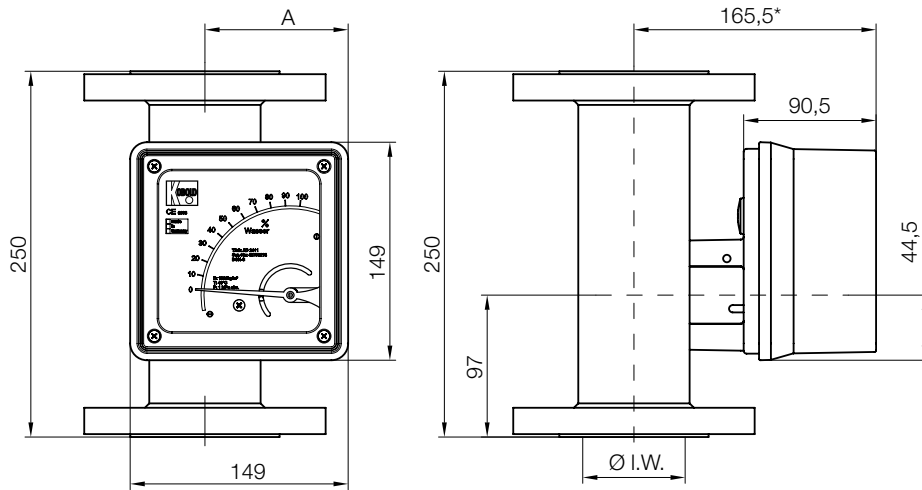

Display: stainless steel

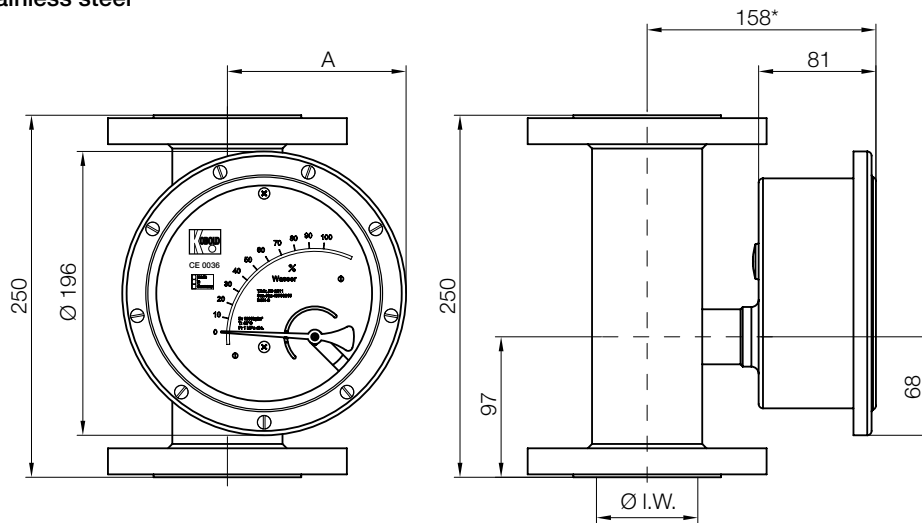

DN	PN	I. W.	A (aluminium)	A (st. steel)
15	40	26	74	100
25	40	32	77	103
40	40	46	85	110
50	40	70	98	123
80	40	102	114	140
100	16	125	127	153
125	16	150	142	166
150	16	159	148	171

Dimensional deviations:

* +100 mm with forward advanced display and generally at DN 125 and DN 150