



200K-SCA-R

Compression Weighing Load Cells

- 200,000 lb/90,720 kg capacity
- Environmentally-sealed (IP68)
- Stainless steel construction
- 35'/10m integral shielded cable

These heavy-capacity compression load cells are ideal for multi-cell applications including truck scales, railroad track scales, and heavy-duty tank weighing systems.

Load cells are fabricated from stainless steel to provide the ultimate in protection when caustic, corrosive or wet environments are encountered.

Load cells are environmentally-sealed for absolute water protection.

MECHANICAL DATA

Rated Capacity, (R.C.) E _{max}	200,000 lb / 90,720 kg
Minimum Dead Load	1,500 lb / 680 kg
Safe Load Limit	150% R.C.
Ultimate Load	300% R.C.
Deflection at R.C.	.01 in / 0.25 mm
Net Weight	33 lb / 15 kg

CERTIFICATE DATA

Issuing Body	NTEP
Certificate Number	89-042A4
Accuracy Class	IIIL
Maximum Number of Load Cell Intervals, n _{max}	10,000
Single/Multiple	M
Minimum Load Cell Verification Interval V _{min} NTEP	6 lb / 2.72 kg

ELECTRICAL DATA

Rated Output	2mV/V
Excitation Voltage, Minimum	10 VDC
Excitation Voltage, Maximum	15 VDC
Cable Length	35 ft / 10 m
Terminal Resistance	
Excitation	450
Signal	480
Zero Load Output	>2% R.C.
Insulation Resistance	>5000 megohms at 50 VDC

ENVIRONMENTAL DATA

Temperature Compensation Range	-10 to +40°C
Operating Temperature Range	-29 to +93°C
Construction & Protection Code	CP-67 HU, IP68
Barometric Pressure Effect on Zero Load Output	<1 v (min)/1kPa

LOAD CELLS

MADE IN USA

SCA

Model 200K-SCA-R

Compression Weighing Load Cells

Model 200K-SCA-R

Capacity: 200,000 lb/90,720 kg

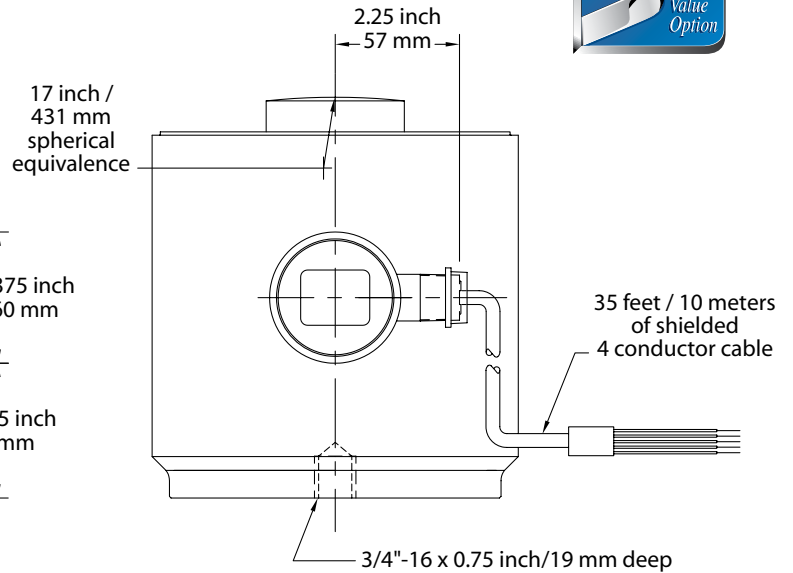
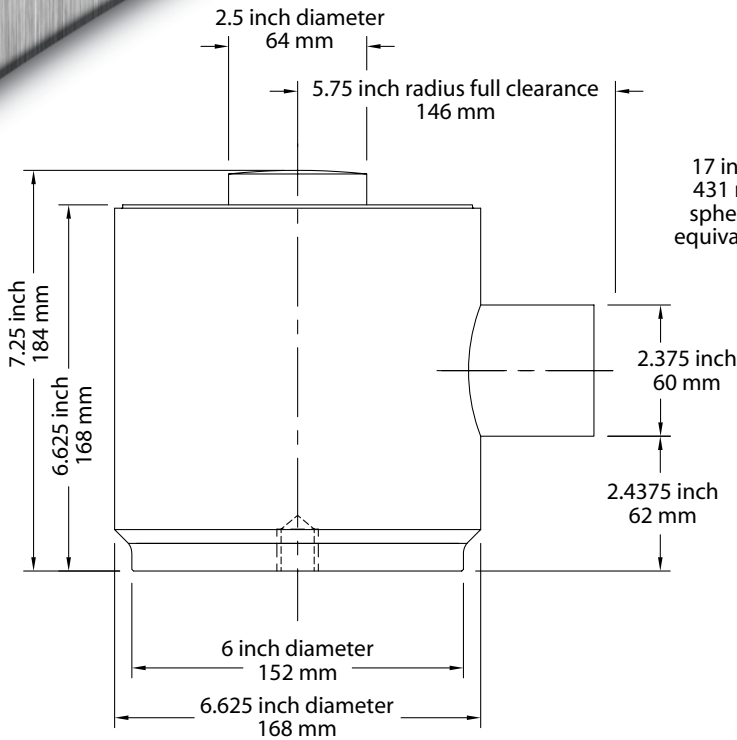

ELECTRICAL INFORMATION



State-of-the-Art Load Cell Manufacturing Facility

ISO 9001 Quality Environment



CERTIFICATIONS

The Model 200K-SCA-R Load Cell meets or exceeds Class IIIIL, 10,000 division accuracy requirements in accordance with NIST Handbook 44. A Certificate of Conformance (Number 89-042A4) has been issued under the National Type Evaluation Program (NTEP) of the National Conference on Weights and Measures.



VCAP CERTIFIED

Cardinal Scale has been found to fully comply with the Verified Conformity Assessment Program (VCAP) administered by the National Type Evaluation Program (NTEP) of the National Conference on Weights and Measures (NCWM).

Cardinal Scale reserves the right to improve, enhance or modify features and specifications without prior notice. All registered trademarks are the property of their respective owners.

Cardinal
Cardinal Scale Manufacturing Co.
203 E. Daugberty, Webb City, MO 64870 USA
Ph: 417-673-4631 or 800-441-4237 • Fax: 417-673-5001
www.CardinalScale.com

SOLD BY:

ControlSystemsUSA.com
Houston, Texas USA
sales@ControlSystemsUSA.com
832-615-3588

